

I. Technical Parameters

- Instrument Accuracy: Class 0.5
- Display Range: -19999 ~ 31000
- Working Power Supply: Default AC220V±10%, 50Hz (Other power supplies need customization)
- Outline Dimensions: 48mm×96mm×87mm
- Mounting Hole Dimensions: 44^{+0.5}mm×92^{+0.5}mm
- Complies with Standard GB/T 22264

II. Panel and Wiring Diagram Description

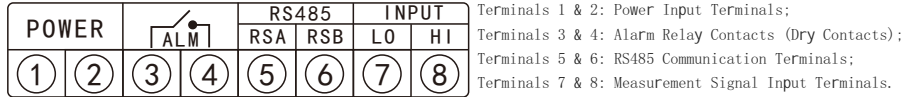
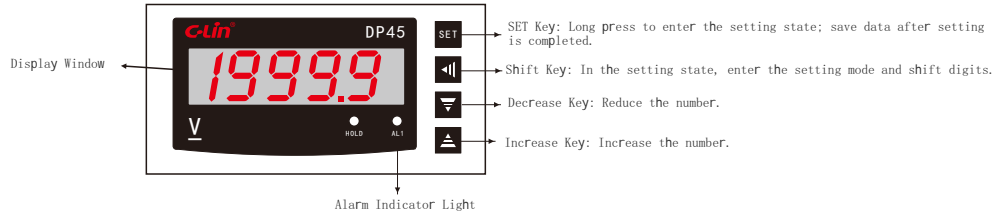

1

Parameter Description

Parameter Symbol	Description of Parameter Symbol	Range and Setting Value	Remarks
AH1	Relay Pick-up Value	-1999.9~31000.0 Default value: 28.0	If AH1 is greater than AL1, the relay picks up when the measurement exceeds AH1 and releases when it is less than AL1; If AL1 is greater than AH1, the relay picks up when the measurement exceeds AL1 and releases when it is less than AH1.
AL1	Relay Release Value	-1999.9~31000.0 Default value: 26.0	
dLY	Relay Delay Pick-up Time	0~99.9 Default value: 2.0	The relay pulls in after a delay for a certain time when the measured value reaches the relay pull-in value.
SFt	Filter Coefficient	0~9 Default value: 0	The filtering range increases progressively from 0 to 9.
ZEco	Small Signal Cut-off	0~999.9 Default value: 0.5	Used to cut off small interference signals.
Add	Communication Address	1~247 Default value: 001	Parameters related to communication settings.
bAd	Communication Baud Rate	9.6K~115.2K Default value: 9.6K (9600)	
Prt	Communication Parity Bit	none (no parity), odd (odd parity), even (even parity) Default: no parity	
LoCk	Data Lock	0000: Unlocked; 0010: Locked menu (view only) Default: 0000	Used to protect setting parameters after the menu is locked.

3

III. Explanation of Parameter Setting Method

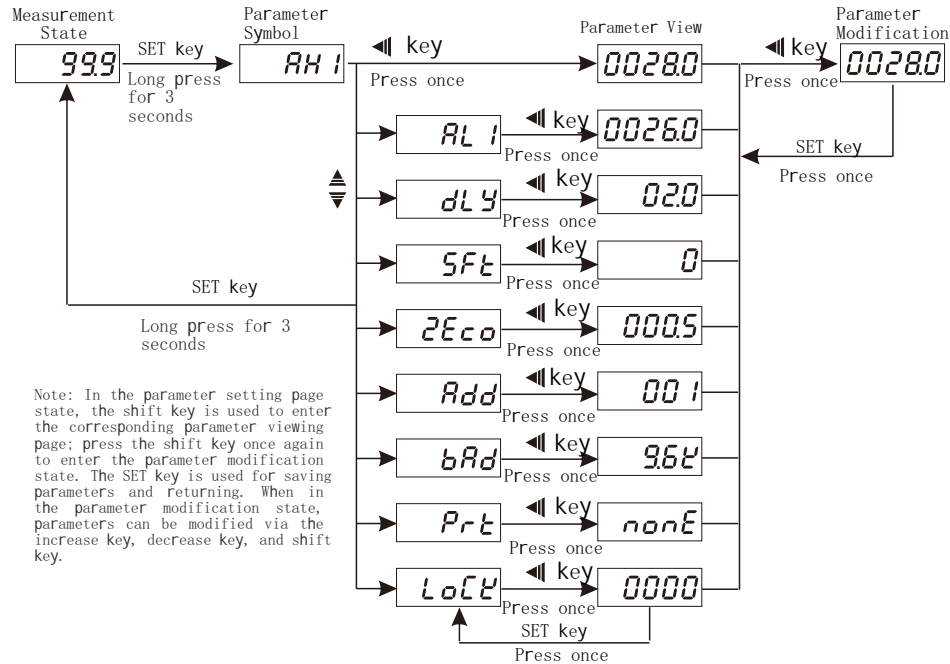

2

IV. Communication Instructions

Protocol Type: MODBUS-RTU

1. Physical Layer : Transmission Mode: 485

Communication Address: 1-247

Communication Baud Rate: 2400, 4800, 9600 (default), 14400, 19200, 28800, 38400, 57600, 115200 Communication Medium: Shielded Twisted Pair

2. Data Link Layer : Transmission Mode: Master-slave Half-duplex

Format of a Data Frame

a. 1 start bit, 8 data bits, even parity, 1 stop bit

b. 1 start bit, 8 data bits, odd parity, 1 stop bit

c. 1 start bit, 8 data bits, no parity, 2 stop bits (default)

Format of a Data Packet

Address Code	Function Code	Data Code	Check Code
8-Bits	8-Bits	N*8-Bits	16-Bits

Explanation of Function Codes

Code	Meaning	Function
03H	Read Holding Registers	Obtain current data of one or more holding registers
06H	Write Single Holding Register	Write single data to a single holding register
16H	Write Multiple Holding Registers	Write multiple data to multiple holding registers
04H	Read Input Registers	Obtain current data of one or more input registers

4

Host-transmitted message format:

Host Transmission Item	Number of Bytes	Transmitted Information	Information Description
Slave Address	1	01H	Send information to the slave at address 01
Function Code	1	16H	Write multiple registers
Start Address	2	0000H	Start from register address 0000H
Number of Variables	2	0004H	4 registers
Data Byte Length	1	08H	The written data has a total of 8 bytes
Written Data 1	2	0002H	Register address 0000H
Written Data 2	2	0001H	Register address 0001H
Written Data 3	2	012CH	Register address 0002H
Written Data 4	2	00C8H	Register address 0003H
CRC Code	2	69D9H	Calculated by the host

Message format returned by slave response:

Slave Response Item	Number of Bytes	Returned Information	Information Description
Slave Address	1	01H	From the host at address 01
Function Code	1	16H	Write multiple registers
Start Address	2	0000H	Start from register address 0000H
Number of Variables	2	04H	4 registers
CRC Code	1	1CC3H	Calculated by the instrument

5

Input Register Address:

Address	Code	Variable Name	Value Range	Read/Write	Data Type	Remarks
0000H	VALDIS	Display Value	/	R	float	Note 6

Remarks:

Note 1: Data in the transmission type register

: 0-20mA, 1: 4-20mA, 2: 0-10mA

Note 2: Data in the baud rate register

0: 4800, 1: 9600, 2: 14400, 3: 19200, 4: 28800, 5: 38400, 6: 57600, 7: 115200

Note 3: Data in the check code register

0: No check, 1: Odd check, 2: Even check

Note 4: Data in the data lock register

0010: Lock menu, 0000: Unlock

Note 5: Parameter saving

After modifying parameters using the communication function, send 1 to this register to save the parameters; otherwise, the parameters cannot be saved (parameters are saved automatically when using communication timing, without the need to modify the save command).

Note 6: Calculation of display value

VALDIS is data represented by a 4-byte binary floating-point number. The format meaning is as follows:

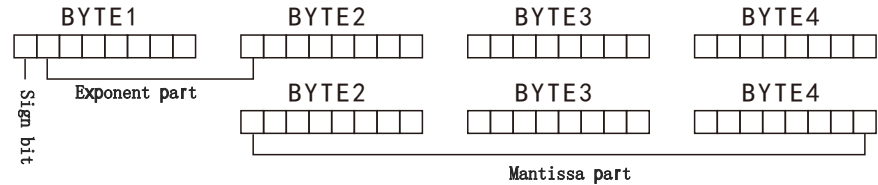

Sign bit: SIGN=0 for positive, SIGN=1 for negative;

Exponent part: $E = \text{Exponent part} - 126$;

Mantissa part: The highest bit of M (mantissa part) is padded with 1; Data

result: $\text{REAL} = \text{SIGN} \times 2 \times M \div (256 \times 65536)$;

7

Holding Register Address:

Address	Code	Variable Name	Value Range	Read/Write	Data Type	Remarks
0000H	AH1	Alarm Pick-up Value	-19999 ~ 31000	W/R	signed int	
0001H	AL1	Alarm Release Value	-19999 ~ 31000	W/R	signed int	
0002H	DLY	Alarm Delay Value	0 ~ 999	W/R	unsigned int	
0003H	CT	Current Change Value	1 ~ 6000	W/R	unsigned int	
0004H	SFT	Filter Coefficient	0 ~ 9	W/R	unsigned int	
0005H	ZERO	Small Signal Cutoff	0 ~ 9999	W/R	unsigned int	
0006H	OBTY	Transmission Output Type	0 ~ 2	W/R	unsigned int	Note 1
0007H	OBL	Transmission Output Lower Limit	-19999 ~ 31000	W/R	signed int	
0008H	OBH	Transmission Output Upper Limit	-19999 ~ 31000	W/R	signed int	
0009H	SLAVE ADDR	Slave Address	1 ~ 247	W/R	unsigned int	
000AH	BAND RATE	Baud Rate	0 ~ 7	W/R	unsigned int	Note 2
000BH	CHECK CODE	Check Code	0 ~ 2	W/R	unsigned int	Note 3
000CH	PASS WORD	Data Lock	0010 or 0000	W/R	unsigned int	Note 4
0034H	SAVE	Parameter Save	0000 or 0001	W/R	unsigned int	Note 5

6

V. Environmental Protection and Other Legal Provisions

In order to protect the environment, when this product or its components are discarded as waste, please properly dispose of them as industrial waste; or hand them over to a recycling station for classified disassembly, recycling and reuse, etc. in accordance with relevant national regulations.



C-Lin
 欣灵电气股份有限公司
 XINLING ELECTRICAL CO., LTD.
 地址: 浙江省乐清经济开发区纬十九路328号
 电话: 0577-6273 5555 传真: 0577-6272 2963
 官网: www.c-lin.cn E-mail: xl@xinling.com
 技术咨询: 400-8236-775



国家高新技术企业 浙江名牌产品

C-Lin 欣灵

使用说明书
 Products Instructions

DP45 Series

Programmable Electrical Measurement and Control Instrument

Thank you very much for using C-Lin brand instruments and meters. Please read the instruction manual before using the product!

09A089Q3