



欣灵电气股份有限公司
XINLING ELECTRICAL CO., LTD.

Address: No. 328, Weishi 19th Road, Yueqing
Economic Development Zone, Zhejiang
Hotline: 0577-62735555
Fax: 0577-62722963
Http: //www.c-lin.cn
Email: C-Lin@xlnl.com
Technical Service Hotline: 400 1663 188

DZ47LE 32/50 Residual Current Circuit Breaker Installation and Operation Instructions

I. Purpose

The DZ47LE series residual current circuit breakers are assembled by DZ47 high - breaking capacity miniature circuit breakers and residual current releases. They are suitable for circuits with an alternating current of 50Hz, a rated voltage up to 400V, and a rated current up to 32A (50A). They have protection functions such as residual current (electric shock), overload, and short - circuit. In addition, over - voltage and under - voltage protection functions can be added according to users' needs. They are mainly used for the protection of building lighting and power distribution systems.

II. Model and Its Meaning

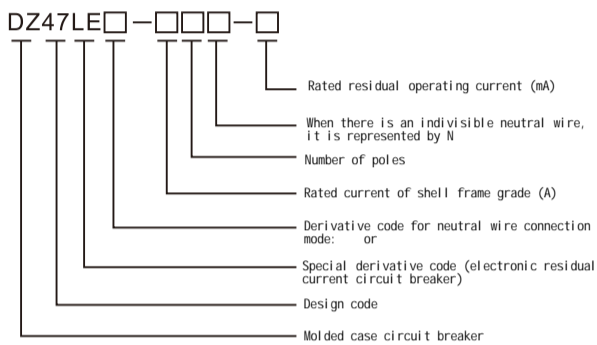

The wiring method with an indivisible neutral wire can be derived into two types: Type I and Type II.
For Type I products, there is no neutral wire terminal at the power supply end, and a flexible wire with a length greater than 200mm is used for leading out.
For Type II products, there is a neutral wire terminal at the power supply end.

III. Product Dimensions

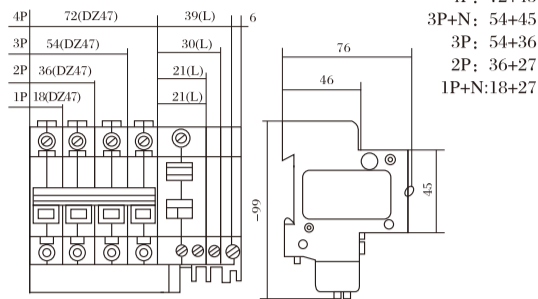

IV. Specifications and Types

Frame Grade Rated Current In(A)	Pole Number	With Neutral Wire	Rated Current In(A)	Rated Short - Circuit Breaking Capacity		Release Type
				Voltage (V)	Breaking Capacity Im(A)	
32	1	N	6, 10 16, 20 25, 32	230	4000	C
	2			400		
	3					
	4	N				
32	1	N	6, 10 16, 20 25, 32	230	4000	D
	2			400		
	3	N				
	4					
50	1	N	40, 50	230	4000	C
	2			400		
	3					
	4	N				

V. Operating Conditions

- Ambient air temperature: -5 ~ +40 , and the average temperature within 24 hours shall not exceed 35
- The altitude of the installation site shall not exceed 2000m.
- The relative humidity of the air at the installation site shall not exceed 50% when the temperature is 40 , and shall not exceed 90% when the average minimum temperature in the wettest month does not exceed 25 .

- The external magnetic field at the installation site shall not exceed 5 times that of the geomagnetic field in any direction.
- Residual current circuit breakers should generally be installed vertically, with the handle upward as the position for connecting the power supply.
- There shall be no significant impact or vibration at the installation location.

VI. Instructions for Use

- The leakage, overload, and short-circuit characteristics of the residual current circuit breaker are all calibrated by the manufacturer and should not be adjusted arbitrarily during use.
- The residual current circuit breaker only provides protection against electric shocks caused by contact between the load side and the phase wire or live enclosure with the earth. It cannot protect against electric shocks caused by simultaneous contact with two wires. Please pay attention to safe electricity use.
- After the residual current circuit breaker operates due to leakage: for DZ47LE , there is a protruding leakage indicator button for indication, and the switch can be closed only after pressing the indicator button; for DZ47LE , there is a red indication, and the switch can be closed directly.
- For the residual current circuit breaker, press the test button "T" once after new installation and after a certain period of operation (generally once a month) to check whether it can work normally.
- On single-pole two-wire and three-pole four-wire residual current circuit breakers, the "N" wire should be connected to the neutral wire so that the electronic circuit can work normally and play a protective role.
- The leakage release must be assembled with the DZ47 circuit breaker to form a residual current circuit breaker before conducting a power-on test; otherwise, the internal components will be burned out.
- Before conducting a power-on inspection test, the power supply terminal (connected via terminals N, 1, 3, and 5 of the circuit breaker) and the load terminal (connected via terminals N, 2, 4, and 6 of the leakage release) should be distinguished according to the circuit diagram and must not be connected incorrectly, otherwise burnout will occur. The auxiliary power supply is introduced from the side terminals of the circuit breaker. The leakage release can only work when the side terminals are connected to the power supply.
- After the residual current circuit breaker trips due to a fault in the controlled circuit, the cause shall be found out, and the fault shall be eliminated before closing the switch.
- Since the standard ambient temperature of the DZ47 circuit breaker is 30±5 , when the ambient temperature changes, its rated current value needs to be corrected, and the correction values are shown in Table 2. If multiple circuit breakers are installed in a sealed cabinet at the same time and the temperature inside the cabinet rises accordingly, the rated current shall be multiplied by a factor of 0.8.
- For the residual current circuit breaker assembled and combined on site with DZ47 circuit breakers and leakage releases of the same brand that meet the requirements of GB10963 in accordance with the manufacturer's instructions, the rated current shall be multiplied by a derating factor of 0.8 (reducing by one current rating).

VII. Basic Specifications and Parameters of Leakage Release are shown in the following table

Table 1

Pole Number	Rated Voltage	Rated Current (A)	Rated Leakage Operating Current (mA)	Rated Leakage Non operating Current (mA)
1P+N	230V	6, 10, 16, 20, 25, 32, 40, 50	30	15
2P			50	25
3P	100		50	
3P+N	300		150	
4P	400V			

Rated Leakage Breaking Time $t \leq 0.1s$
Rated Residual Making and Breaking Capacity $\Delta I_m: 2000A$ GB16917.1

When the ambient temperature changes, its rated current value shall be corrected accordingly. See Table 2 for details.

Table 2

Temperature	10℃	15℃	20℃	25℃	30℃	35℃	40℃
Rated Current							
6A	6.54	6.44	6.30	6.80	6.00	5.82	5.64
10A	10.90	10.75	10.50	10.30	10.00	9.60	9.30
15A	16.35	16.12	15.72	15.45	15.00	14.55	14.10
20A	21.80	21.50	21.0	20.60	20.00	19.40	18.80
25A	27.25	26.87	26.30	25.75	25.00	24.25	23.25
32A	34.88	34.40	33.60	32.96	32.00	31.04	30.08
40A	44.80	43.60	42.80	41.60	40.00	38.40	36.80
50A	56.00	54.50	54.00	52.00	50.00	48.00	46.00
63A	70.56	68.67	67.41	65.50	63.00	60.48	58.59

VIII. Assembly Diagram of DZ47 Circuit Breaker and Leakage Release

