

Temperature Control Mode Setting

In the temperature display state, press the and keys simultaneously and hold for more than 5 seconds to enter the working mode switching state, where "H--" will flash. Press the key or key to adjust between P1 and P2. Adjust to the working mode suitable for you according to the following table, and then press the [Set] key to return to the temperature measurement state. (The factory default setting is P2 cooling mode; the default upper limit temperature of the instrument is 30 °C, and the lower limit temperature is 25 °C.)

| Working Mode | Working State Switching (Adjusted by Toggle Switch) | Control Relationship | Additional Instructions |
|----------------------------|---|---|---|
| P1 Single-Limit Control | Heating Type | When the measured value < set value, the switch is turned on; when the measured value > set value, the switch is turned off. | Suitable for simple low-power heating control, only need to set a temperature limit value. For example: small electric heaters, water heaters, etc. |
| | Cooling Type | When the measured value > set value, the switch is turned on; when the measured value < set value, the switch is turned off. | Suitable for simple low-power cooling control, only need to set a temperature limit value. For example: small cooling devices, fans, etc. |
| P2 Double-Limit Control | Heating Type | When the measured value < lower limit set value, the switch is turned on; when the lower limit set value < measured value < upper limit set value, the switch state remains unchanged; when the measured value > upper limit set value, the switch is turned off. | Suitable for more complex high-power heating control, need to set upper and lower limit temperatures to avoid frequent start-stop of control equipment and extend its service life. For example: industrial heating equipment such as electric ovens, electrolysis devices. |
| | Cooling Type | When the measured value > upper limit set value, the switch is turned on; when the lower limit set value < measured value < upper limit set value, the switch state remains unchanged; when the measured value < lower limit set value, the switch is turned off. | Suitable for more complex high-power cooling control, need to set upper and lower limit temperatures to avoid frequent start-stop of control equipment and extend its service life. For example: industrial cooling equipment such as breeding fans, cold storage. |

6

Operation Setting

Setting Upper and Lower Limit Temperatures: In the temperature display state, press the set key once. When "H--" is displayed, enter the upper limit temperature setting, and the upper limit temperature display will flash. Press or to adjust the upper limit temperature value. Press the set key again. When "L--" is displayed, enter the lower limit temperature setting, and the lower limit temperature display will flash. Similarly, press or to adjust the lower limit temperature value. After setting, press the set key again to return to the temperature measurement state. Note: If working mode P2 is selected, when setting the upper and lower limit temperature data, the order and value magnitude can be ignored. The system will automatically take the larger value as the upper limit and the smaller one as the lower limit. If working mode P1 is selected, "H--" is displayed, and only one temperature value needs to be set.

Auto Exit From Setting State: If there is no normal operation to exit the setting state during data setting, and no key is pressed for 30 seconds midway, the system will automatically exit the setting state and return to the temperature measurement state. Meanwhile, the data of this setting operation is saved automatically.

Output Delay and Temperature Correction

The output port has a judgment and comparison delay of about 2 seconds. The output port will only execute the action when each measurement result meets the action requirement of the output port within 2 seconds; otherwise, it will not. This is to avoid misoperations of the output port caused by fluctuation interferences such as lightning induction, start and stop of large equipment, etc.

Fault Safety Guarantee Measures: If the sensor has an open-circuit fault, "HHH" will appear on the display immediately. If the sensor and its leads are short-circuited, "LLL" will appear on the display immediately. To prevent adverse consequences caused by sensor open circuit or short circuit, the control output port will be closed with priority.

Long press the key for 3 seconds to enter the temperature correction mode "E--": Correction range: -19.9 ~ +19.9 °C.

6

VIII. Precautions

1. During the use of the instrument, there should be no corrosive gas on site. The sensor must not work in an environment with corrosion or a temperature exceeding 100 °C to prevent damage to the lead wire (special wiring).

2. If it is really necessary to use the sensor in slightly corrosive gas or liquid, prepare multiple spare sensors for regular replacement. Meanwhile, regularly check the condition of the sensor.

3. In some cases, it is required to control a 380V three-phase AC power supply. At this time, the instrument can be installed in a low-voltage control cabinet together with an AC contactor for use.

(Note that there must be a neutral wire in the control cabinet, and the wiring must be installed by professional electricians. For the wiring method, please refer to the wiring diagram in this manual.)

4. Product packaging: Packed in a paper box, including 1 temperature controller (with a sensor attached) and 1 instruction manual.

IX. Order Instructions

When placing an order, please specify the required product model, working power supply, and sensor wire length in detail.

For example: HH-1; AC220V; 2.5m (default).

7

| | |
|--|------------------|
| 产品合格证 | 符合标准: GB/T 13639 |
| | 检验员: 检 01 |
| | 出厂日期: 见产品或盒贴出厂编号 |
| | 本产品经检验合格,准予出厂。 |
| 欣灵电气股份有限公司 XINLING ELECTRICAL CO., LTD. | |

C-Lin

欣灵电气股份有限公司
XINLING ELECTRICAL CO., LTD.

Address: Liu Shi Economic Development Zone, Yueqing, Zhejiang
Tel: 0577-6273 5555 Fax: 0577-6273 2963
Official Website: www.c-lin.cn E-mail: C-Lin@xln.com
Customer Service Hotline: 400-828-8746



RECYCLABLE

National High-Tech Enterprise (China) | High-Tech Product

C-Lin 欣灵

使用说明书
Products Instructions

HH-1

Instruction Manual for Heating and Cooling Attendant

Thank you very much for using C-Lin Brand Instrument. Please read the Instruction manual before using the product!

09A014O1

I. Product Overview

The HH-1 Cooling and Heating Attendant (hereinafter referred to as the "instrument") is powerful, with a beautiful and reasonable appearance, and its shell flame retardancy meets safety requirements. The instrument uses an MCU as the core for temperature measurement, and features a three-digit high-brightness red LED digital display for temperature values, ensuring stable and reliable operation. Within the temperature measurement range (-20 ~+99.9), it can control the load on/off according to the temperature range set by the user. The user-set temperature parameters are stored in the chip, unaffected by power outages, and no data is lost in case of power failure. There are 4 temperature control modes in total, suitable for both heating control and cooling control, meeting the needs of most application scenarios. Forward heating is applicable to electric heaters, electric ovens, electroplating, electric water heaters, over-temperature protection, etc. Reverse cooling is applicable to air conditioning refrigeration, exhaust fans, etc. Users are reminded that before using the instrument for the first time, they must set a temperature control mode suitable for them; otherwise, it cannot work normally. For specific operations, please refer to the section "V. Temperature Control Mode Setting". This series of instruments complies with the standard GB/T 13639.

II. Main Technical Indicators

1. Rated Voltage: AC220V±10% (50Hz/60Hz)
2. Temperature Measurement Range: -19.9 ~99.9
3. Temperature Control Range: -19.9 ~99.9
4. Temperature Error: ±1.0 FS
5. Display Resolution: 0.1
6. Output Mode: Active output, maximum load: AC220V/3A (resistive) (available for high-power users upon request)
7. Shell Material: High flame-retardant engineering plastic
8. Installation Method: Terminal wiring (three fixing methods: guide rail, wall-mounted, hanging)
9. Dimensions (Length × Width × Depth): 120×72×46mm
10. Temperature Sensor Type: Dedicated sensor, standard wiring length 2.5m

1

IV. Installation and Wiring

Wiring Method

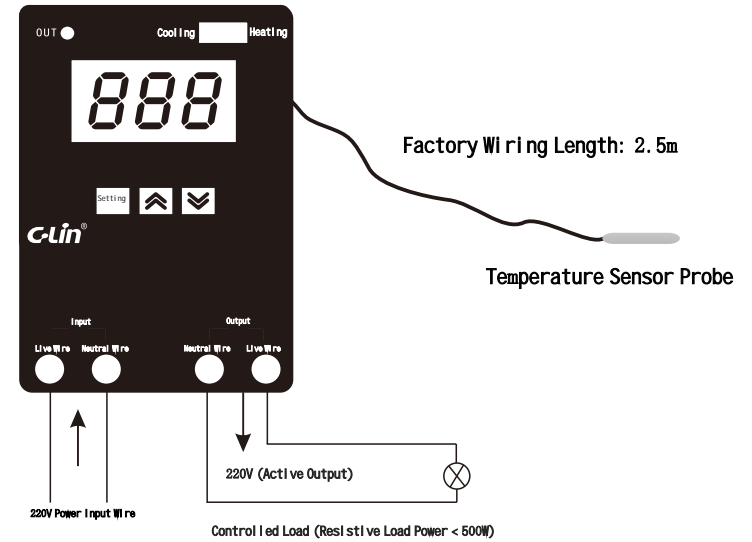

3

III. Panel Description

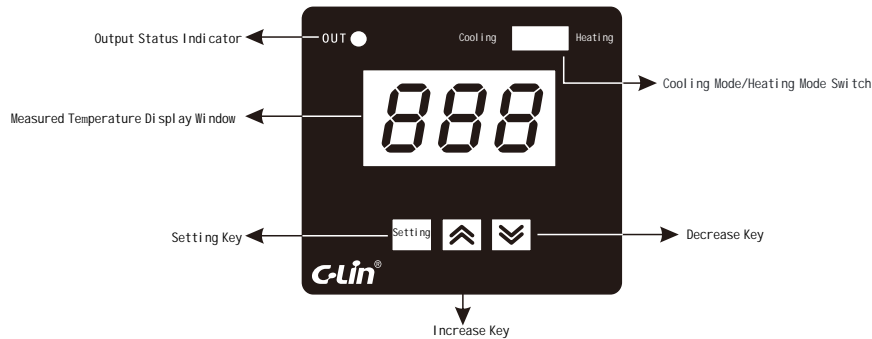

Temperature Setting Interface

Press the Setting Key once to enter the temperature setting interface. You can change the set temperature value using the [Up] Key and [Down] Key.

Cooling/Heating Mode Switch

Switch between cooling and heating modes (by toggling the switch).

Temperature Control Mode Setting Interface

Long-press the [Up] Key and [Down] Key simultaneously to enter the mode setting interface. You can change the mode using the [Up] Key and [Down] Key. (P1 is single-limit mode, P2 is dual-limit mode)

Output Indicator : When the instrument is in working status, the green light is on.

2

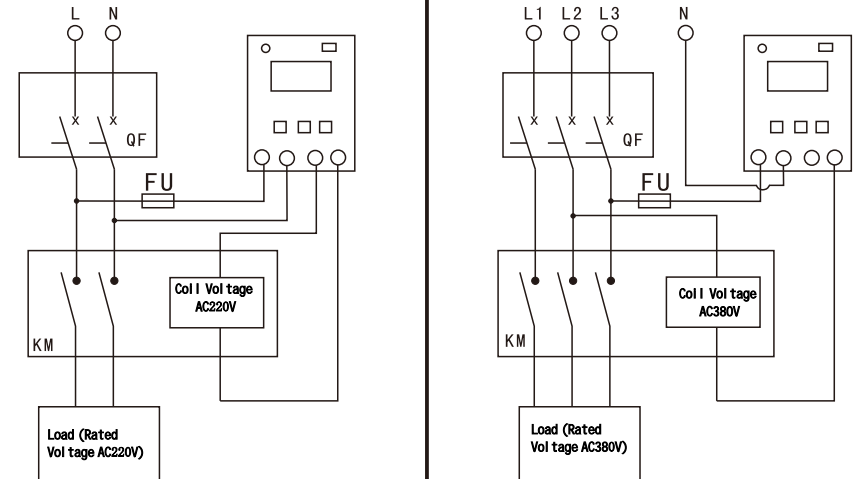

Description:
KM: AC Contactor
FU: Fuse
QF: Circuit Breaker

Description:
KM: AC Contactor
FU: Fuse
QF: Circuit Breaker

4