

VII. Outline Structure and Description of Condensation Sensor

1. Sensor Outline Drawing

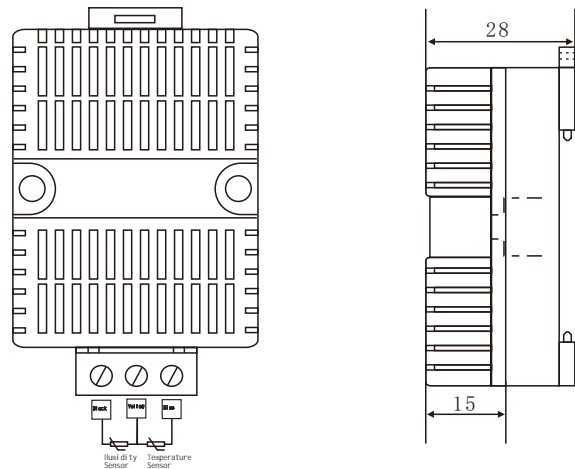

5

. Precautions for Use

- Each product includes a kit: 1 controller, sensor cable (standard length is 3 meters, extendable and customizable), 1 dedicated condensation sensor, panel mounting accessories, guide rail mounting accessories, and an instruction manual.
- Wiring and power-on can only be performed on the premise of carefully reading the Instruction Manual.
- Regarding the humidity sensor:
 - During installation, the humidity sensor should be in good contact to ensure its sensitivity.
 - When testing the humidity sensor (taking dehumidification as an example), a humidity generator can be used, or you can breathe on the condensation sensor for about 5 seconds (do not immerse the sensor directly in water or drip water onto it). The humidity indicator light on the controller will turn green and the load will start working; when away from water vapor, the humidity indicator light will turn red and the load will stop working.
 - When testing the temperature sensor, a high-precision resistance measuring device (such as a digital bridge, multimeter, etc.) can be used. Measure the resistance at both ends of the temperature sensor wiring. At room temperature (25 °C) and 0 °C, the resistances are 10.00KΩ and 32.834KΩ respectively.
 - Avoid placing the temperature and humidity sensor under water vapor above 60 °C for a long time.
 - Cleaning conditions for the temperature sensor: Solvents must not be used; cotton swabs can be used to gently wipe under water vapor.
- The temperature and humidity controller can be used with the heater of our company (HHJRD).

. Environmental Protection and Other Legal Provisions

To protect the environment, when this product or its components are scrapped, they should be properly disposed of as industrial waste; or handed over to a recycling station for classified disassembly, recycling and reuse in accordance with relevant national regulations.

7

2. Outline Dimensions

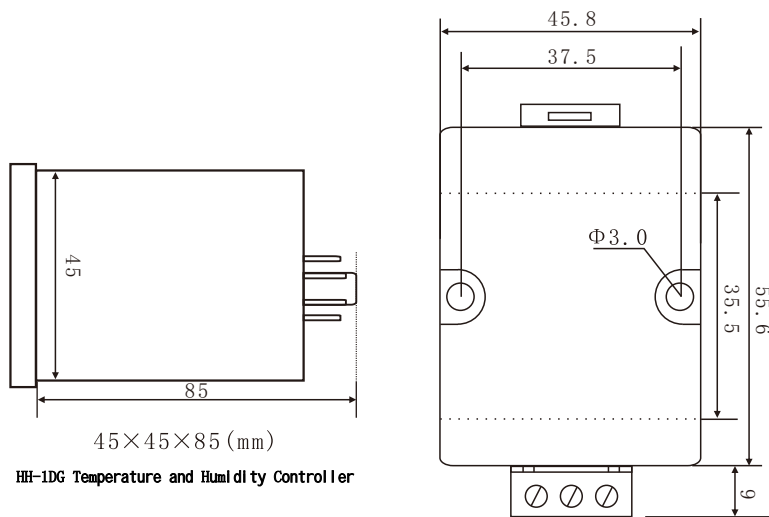

HH-1DG Temperature and Humidity Controller

Temperature and Humidity Sensor

6

X. Ordering Information

When placing an order, please specify the required product model, working mode, working power supply, and sensor cable length in detail.
For example: HH-1DG, Heating and Dehumidification, AC220V, 3 meters.

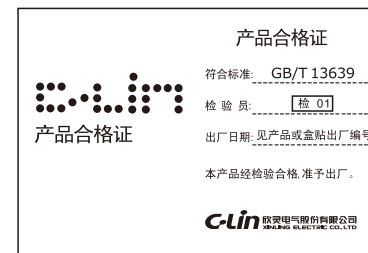

C-Lin[®]
欣灵电气股份有限公司
XINLING ELECTRICAL CO., LTD.
 Address: No. 328, Weishi 19th Road, Yueqing Development Zone,
 Yueqing, Zhejiang Province
 Tel: 0577-6273 8555 Fax: 0577-6272 2963
 Official Website: www.c-lin.cn E-mail: C-Lin@xlnl.com
 Technical Consultation: 400-826-776



Official English Document, Please Refer to the Chinese Version

C-Lin 欣灵

使用说明书
Products Instructions

HH-1DG
Series Temperature and Humidity Controller User Manual

Thank you very much for using C-Lin Instruments. Please read the user manual before using the product!

09A001Q0

. Product Overview

The HH-1DG series condensation controller is mainly applied in occasions with humid working environments and water vapor generation, focusing on power equipment, such as outdoor terminal boxes, high and low voltage control cabinets, ring main switchgear, underground substations, box-type substations, circuit breaker mechanism boxes, instrument boxes, etc. It can effectively prevent equipment failures caused by low temperature and high temperature, as well as creepage and flashover accidents caused by dampness or condensation, ensuring the efficient and safe operation of automated operations.

This model of instrument meets the relevant requirements of GB/T 13639.

. Product Functional Features

1. Adopts thermal and humidity-sensitive elements, with fast response speed and high measurement accuracy.
2. Produced and processed with Surface Mount Technology (SMT), the product has reliable performance and good stability.
3. Ultra-small volume, easy to install.
4. Installation methods: standard guide rail installation, panel installation.
5. Active output drives one load (active output driving two loads needs to be customized).

. Product Technical Indicators

1. Working power supply: AC220V (special voltage can be customized). Power consumption 2W.
2. Working modes: heating and dehumidification, cooling and dehumidification, heating and humidification, cooling and humidification.

①

. Product Panel Structure and Description

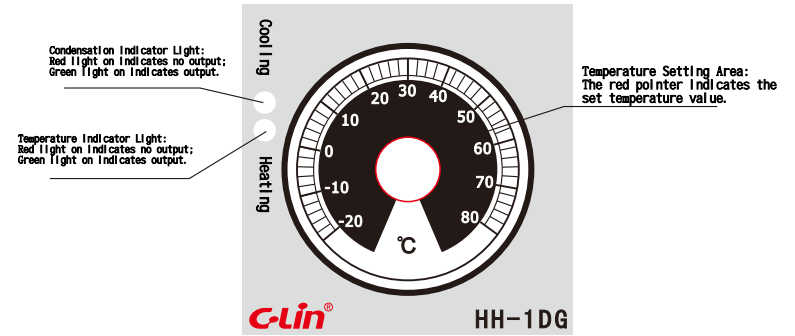

1. Temperature Indicator Light:
In cooling mode, when the temperature exceeds the set value, the green light turns on, and the relay's active output activates to start cooling.
In heating mode, when the temperature is below the set value, the green light turns on, and the relay's active output activates to start heating.
Control hysteresis: 5 °C (please specify cooling or heating mode when placing the order).
2. Humidity Indicator Light:
In dehumidification mode, when the humidity exceeds 93%RH, the humidity green light turns on, and the relay's active output activates to start dehumidification. When the humidity drops below 75%RH, the humidity red light turns on, and the relay's active output deactivates to stop dehumidification.

③

3. Temperature Control : The temperature can be set via a potentiometer, and it operates in the corresponding mode; the hysteresis is 5-8 .
4. Humidity Control : According to the working mode, the upper humidity limit is 93%RH; the lower humidity limit is 75%RH.
5. Control Method : Active maximum output current: 5A, AC250V resistive load.
6. Outline Dimension : 48×48×114 (mm), Mounting Hole Dimension: 45^{+0.5} × 45^{+0.5} (mm).
7. Working Environment : Temperature range: -10 -50 , relative humidity < 85% in occasions without corrosive gas.

. Product Wiring Diagram

▲ Wiring Diagram for Single-Load Product

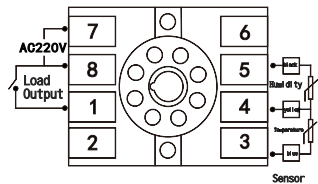

▲ Wiring Diagram for Dual-Load Product

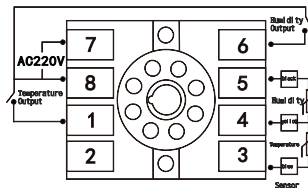

Note: The labels "Black", "Yellow", and "Blue" on the temperature and humidity sensor terminals correspond to terminals 5, 4, and 3 on the guide rail base respectively.

②

VI. Instrument Operating Mode Description

1. Heating and Dehumidification

For temperature: When the temperature is lower than the set value, the green light turns on and the instrument outputs; when the actual measured temperature is higher than the set value, the red light turns on and the instrument stops outputting. For humidity: When the humidity is greater than 93%RH, the green light turns on and the instrument outputs; when the humidity is less than 75%RH, the red light turns on and the instrument stops outputting.

2. Cooling and Dehumidification

For temperature: When the temperature is lower than the set value, the red light turns on and the instrument stops outputting; when the actual measured temperature is higher than the set value, the green light turns on and the instrument outputs. For humidity: When the humidity is greater than 93%RH, the green light turns on and the instrument outputs; when the humidity is less than 75%RH, the red light turns on and the instrument stops outputting.

3. Heating and Humidification

For temperature: When the temperature is lower than the set value, the green light turns on and the instrument outputs; when the actual measured temperature is higher than the set value, the red light turns on and the instrument stops outputting. For humidity: When the humidity is greater than 93%RH, the red light turns on and the instrument stops outputting; when the humidity is less than 75%RH, the green light turns on and the instrument outputs.

4. Cooling and Humidification

For temperature: When the temperature is lower than the set value, the red light turns on and the instrument stops outputting; when the actual measured temperature is higher than the set value, the green light turns on and the instrument outputs. For humidity: When the humidity is greater than 93%RH, the red light turns on and the instrument stops outputting; when the humidity is less than 75%RH, the green light turns on and the instrument outputs.

Note: For a meter with one load output: Its temperature and humidity outputs control one load. For a meter with two load outputs: Its temperature and humidity respectively control one load each.

④