

VII. Function Setting

First, hook the concave part on the right side of the cover plate with your hand (as shown in the left figure below) and pull it out gently. After opening the cover plate, it will be as shown in the right figure below (be careful not to use excessive force to avoid breaking the cover plate), and then set the numbers as required.

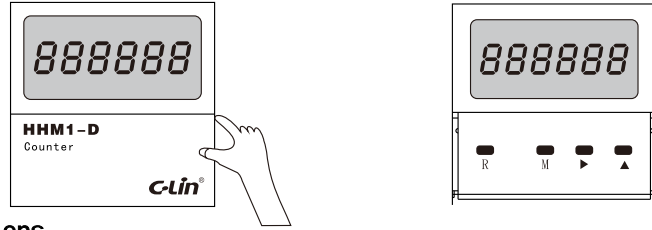

1. Key Functions

"M" Function Key: The display shows the preset value (setting range: 1~999999).

Long-press the "M" key for 4 seconds: The display shows the quantity value coefficient, R2, R3, R4, R5.

Description: Quantity Value Coefficient: Setting range: 0.001~9.999

R2: R2---L Low-frequency counting (counting frequency 30 times/second).

R2---H High-frequency counting (counting frequency 1000 times/second).

R3: R3---U Forward counting (count display: 1, 2, 3, 4, 5...)

R3---d Reverse counting (count display: 100, 99, 98, 97...).

R4: R4---N = N mode R4---R = R mode

R4---C = C mode R4---f = T mode (with advance quantity)

R4---F = F mode R4---H = X mode

R5: R5-00.0 = Automatic reset time (setting range: 0.1s~99.9s) (only for C and R modes).

000000 = Advance quantity for N mode (this setting applies to T mode).

"▶" Shift Key: Press this key to shift digit positions (e.g., shift units to tens, or tens to hundreds).

" " Increment Key: Press this key to increment the selected (flashing) digit.

"R" Reset Key: Press this key to reset the displayed number and count output status to the initial state.

2. Preset Value Setting

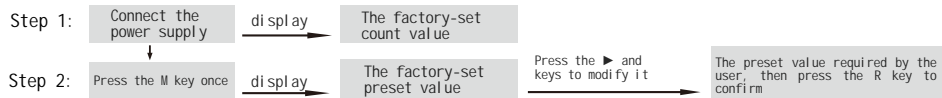

3. Parameter Setting (No fifth step for N, F, X modes; only applicable to C, R, T modes)

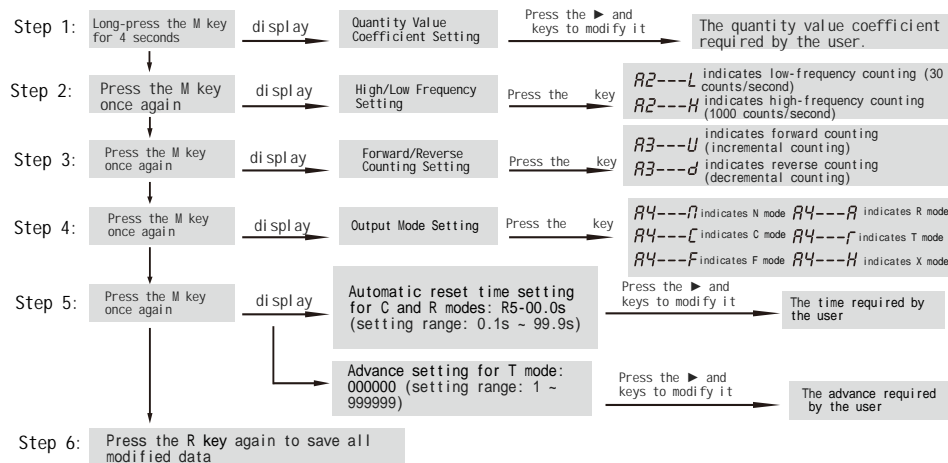

Example: Given a preset value of 1268.88, a quantity coefficient of 0.250, a high-frequency counting signal, a forward counting mode, and output modes of N, F, and C (with an automatic reset time of 15.8 seconds), the display codes are as follows:

N mode	1268.88	0.250	R2---H	R3---U	R4---N	Press the R key once at last to save the data.
F mode	1268.88	0.250	R2---H	R3---U	R4---F	Press the R key once at last to save the data.
C mode	1268.88	0.250	R2---H	R3---U	R4---C	R5-15.8 Press the R key once at last to save the data.

VIII. Instructions for Use

- The "R" key serves as both a reset key and a confirmation key. After each parameter setting, press this key to confirm; only then will the device operate with the newly set parameters.
- For contact signal input counting: If false counting occurs due to poor contact or contact bounce at the input terminal, connect a 4.7μF/50V electrolytic capacitor between counting signal input terminals and . Ensure terminal connects to the negative pole of the capacitor, and terminal connects to the positive pole.
- Keep the counting signal input line and reset control line as short as possible. Avoid routing them in the same conduit or twisting them with power lines/power cables. If necessary, use shielded wires, and never apply voltage to the reset terminal to prevent product damage.
- Display precision and counting range depend on the quantity coefficient setting:
 - If the quantity coefficient is set to 0.002 (accurate to the 3rd decimal place), the counting range is 0.002 ~ 999.999.
 - If the quantity coefficient is set to 0.2 (accurate to the 1st decimal place), the counting range is 0.2 ~ 99999.9.

IX. Ordering Instructions (Products with T mode require customization)

When placing an order, specify: product model, operating voltage, output mode, and quantity.

Examples: 1) HHM1-D (new type), AC220V, N, C, F, R, X modes, 500 pieces
2) HHM1-D (new type), AC220V, N, C, F, R, X, T modes, 500 pieces (customization required)

4



C-Lin
欣灵电气股份有限公司
XINLING ELECTRICAL CO., LTD.
地址: 浙江省乐清经济开发区纬十九路328号
电话: 0577-62735555 传真: 0577-62722963
官网: www.c-lin.cn 邮箱: xl@xinling.com
技术咨询: 400-8236-775



国家高新技术企业 浙江著名商标

C-Lin 欣灵

使用说明书
Products Instructions

HHM1-D (New Type)
Counting Relay N/C/F/R/X/T Modes
Thank you for choosing C-Lin products. Please read the instruction manual carefully before use.

29A033P0

I. Overview

The HHM1-D (new type) counting relay is suitable for use as a counting component in control circuits with an AC frequency of 50/60Hz, a rated working voltage of 380V and below, or a DC working voltage of 24V. It connects or disconnects the circuit according to the preset number.

It adopts a single-chip microcomputer circuit, an EEPROM memory, photoelectric isolation of counting signals, and a 6-digit LED digital display. It has the advantages of a wide counting range, multiple counting signal inputs, multiple output working modes, forward/reverse counting, a power-off memory duration of up to 10 years, and stable and reliable counting performance.

This product meets the requirements of GB/T 14048.5.

II. Main Technical Data

- Operating voltage (control power supply voltage): AC380V, 220V, 110V, 36V, 24V at 50/60Hz. The allowable voltage fluctuation range is (85% - 110%) Ue; DC24V.
- Counting range: 1 - 999999 (quantity value coefficient: 0.001 - 9.999);
- Counting signals: a) Contact signals: relay contacts, travel switches, etc.; b) Level signals: pulse levels (DC4V - 30V valid);
- Sensor signals: photoelectric switches, proximity switches, Hall switches;
- Counting frequency: a) Low-frequency counting: 30 times/second, minimum signal pulse 15ms; b) High-frequency counting: 1000 times/second, minimum signal pulse 0.5ms, signal duty cycle is 50%;
- Counting method: Forward/reverse counting;
- Power-off memory: 10 years;
- Reset method: Button reset and short-circuit reset of terminals and ;
- Ue/Ie: Under the usage category, each rated operating voltage Ue/rated operating current Ie: AC-15 Ue: AC250V, Ie: 3A;
- Output mode: N, C, F, R, X, T modes (T mode needs to be customized);
- Contact capacity: 3A at AC250V (resistive);
- Rated heating current Ith: 5A;
- Rated insulation voltage Ui: 400V;
- Rated impulse withstand voltage Uimp: 2.5KV;
- Pollution level: Level 3;
- Protection class: Front panel IP20;
- Ambient temperature: -5°C - +40°C;
- Relative humidity: 90%;
- Altitude: 2000m;
- Installation method: Panel-mounted;

III. Wiring Diagram

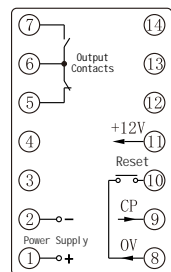

Wiring Diagram for Five Modes: N, C, F, R, X

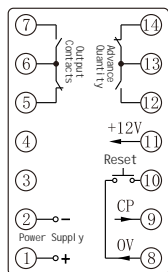

Wiring Diagram for Six Modes: N, C, F, R, X, T

Note: and are power input terminals (for DC, is the positive pole and is the negative pole); and are normally closed contacts, and and are normally open contacts; is 0V (GND); is the counting signal input terminal; is the reset terminal; is the DC12V 30mA (max) sensor auxiliary power output terminal; , , and are the advance output contacts (only for T mode), among which and are normally open contacts, and and are normally closed contacts.

IV. Outline and Installation Dimension Diagram (Installation Opening Dimension: 67.5^{+0.5} × 67.5^{+0.5}mm)

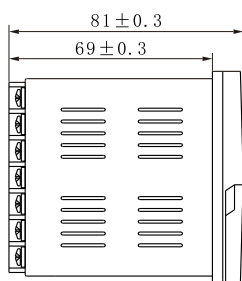
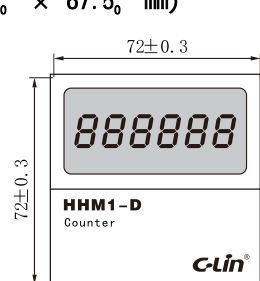

①

V. Counting Signal Input

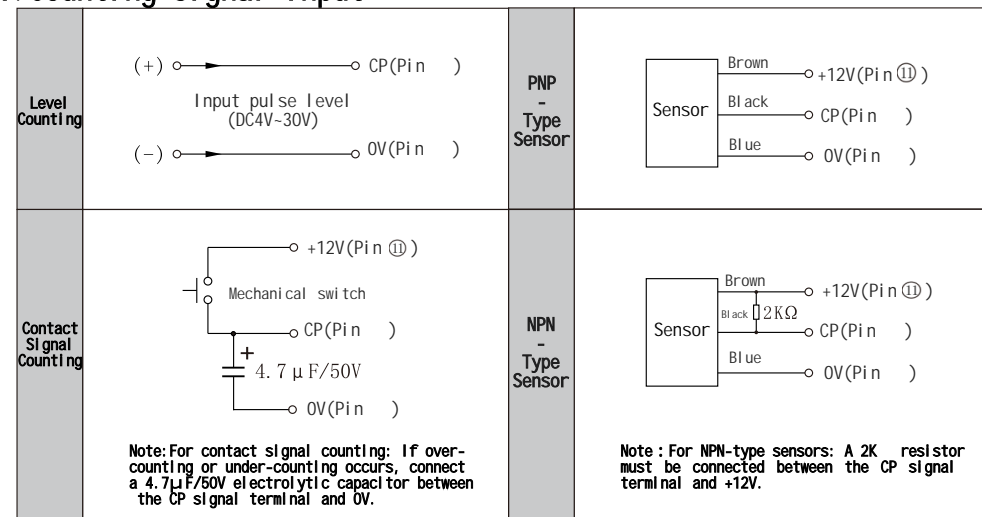

Note: Priority is given to DC (10-30V) PNP normally open photoelectric switches or proximity switches. If an NPN-type sensor is used, connect an external 2K resistor as shown in the above diagram (each meter counter is randomly supplied with one 2K resistor and one 4.7μF/50V electrolytic capacitor at the factory).

VI. Output Mode Diagrams

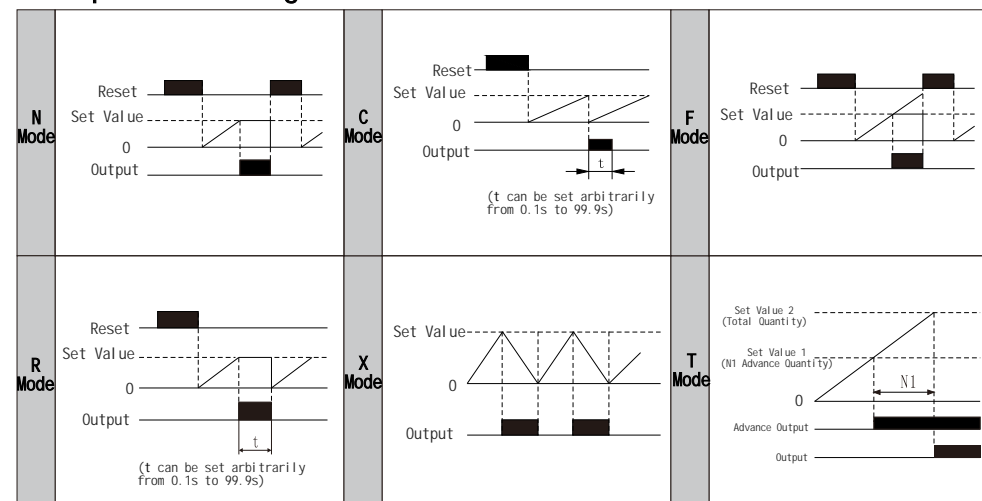

N mode: After reaching the set value, counting stops and the relay pulls in. Press the reset button to reset to zero and start counting again.

C mode: After reaching the set value, the display automatically resets to zero and restarts counting. Meanwhile, the relay pulls in and releases after t seconds.

F mode: After reaching the set value, counting continues, but the relay pulls in. Press the reset button to reset to zero and start counting again.

R mode: After reaching the set value, a short pulse is output for t seconds. Counting restarts after the pulse ends.

X mode: After reaching the set value, the relay pulls in and releases when counting down to 0, cycling repeatedly.

T mode: A mode with advance quantity and two-way output.

Note: Modes N, F, X, and T require manual reset, while modes C and R support automatic reset.

②