

I. Overview

The HHY14 Float Level Relay (hereinafter referred to as "the relay") is a switch designed to regulate liquid levels in tanks, troughs, or wells. It is an environmentally friendly float switch featuring automatic adjustment, easy operation, convenient installation, safety, reliability, and maintenance-free performance. It is suitable for both water supply and drainage control and resistant to sewage, making it widely applicable in containers such as pools, tanks, troughs, and jars in households, factories, mines, and other settings. For example: Connect two relays in series—install one in a water tower and the other in a well to control the water pump. This prevents pump damage from dry running (caused by insufficient water supply, see Figure 5). Alternatively: Connect three relays in series—install one in a water tower, one in a filtration tank, and one in a river (or well). This enables simultaneous control of two water pump units.

II. Main Technical Data

1. Rated Current and Voltage: 10(8A) 250V - 10(4A) 380V (resistive load).
2. Operating Temperature: 0 (non-freezing) < water temperature 80 .
3. Control Range: 0.2m.
4. Pollution Degree: Class 3.
5. Lead Length: 1m, 2m, 3m, 4m, 5m, 10m (special lengths and materials can be customized as required).

III. Installation Method of the Weight

1. Threading and Removing the Plastic Ring: Thread the cable of the float switch through the downward - protruding circular hole at the center of the weight. Gently push the weight so that the plastic ring embedded above the hole falls off due to the thrust from the cable head. (If needed, a flathead screwdriver can also remove the plastic ring.) Then, slide the removed plastic ring onto the cable at the desired position to fix the weight and set the liquid level (see Figure 1).

2. Securing the Weight: Gently push the weight to pull out the cable until the center of the weight catches the plastic ring. The weight will not slip as long as it is lightly fastened to the plastic ring. If the plastic ring is damaged or lost, a bare copper wire of the same diameter can be fastened onto the cable as a replacement (see Figure 2).

3. Additional Fixing and Cable Precautions: During use, further secure the weight to the cable (by clamping both top and bottom) or to the inner wall of the container using a copper wire or similar material. This prevents the weight from sliding and affecting liquid level control. Route the cable directly to the control box and avoid intermediate joints. If joints are unavoidable, never immerse the cable joints in the liquid.

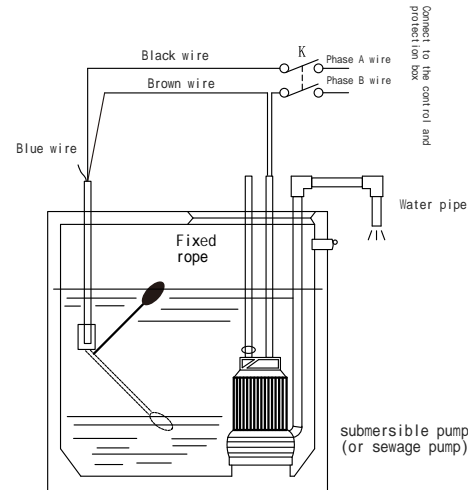

Figure 1



Figure 2

IV. Installation and Wiring Method



This diagram shows the use of an HHY14 relay to control a single-phase water pump for automatic drainage.

Figure 3

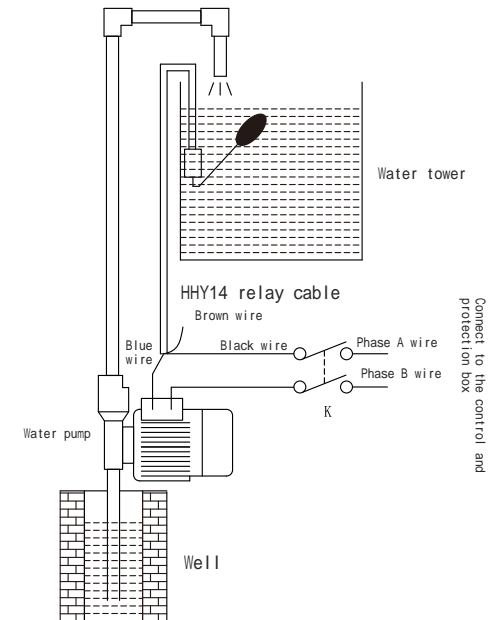

This diagram shows the use of an HHY14 relay to control a single-phase water pump for automatic water supply. In case the water source is abnormal and fails to prevent damage to the water pump equipment, please refer to Figure 5.

Figure 4

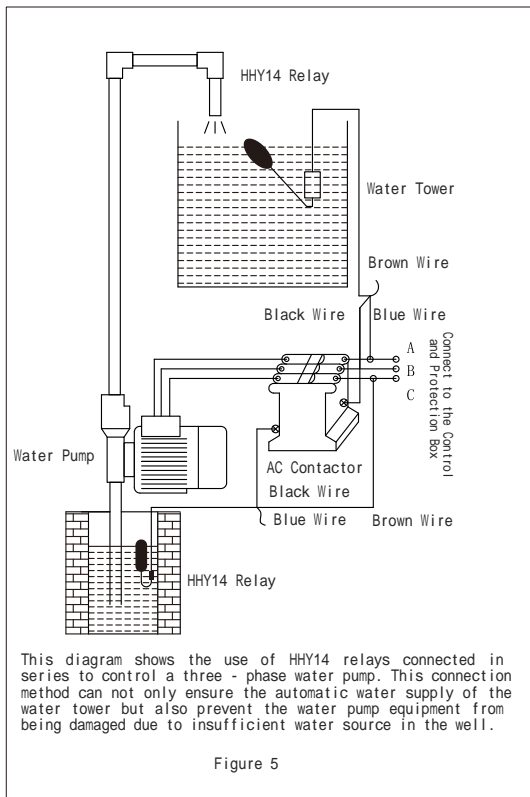

V. Precautions

1. The above wiring methods are for reference only. Unused wires must be provided with absolute insulation.
2. For single - phase water pumps with a power exceeding 1kW, AC contactors shall be used for capacity expansion.

VI. Ordering Instructions

It is necessary to specify the product model, voltage rating, and quantity. If there are special requirements, they should be additionally noted.
For example: HHY14, AC220V, 100 pieces.



C-Lin®
欣灵电气股份有限公司
XINLING ELECTRICAL CO., LTD.
 地址: 浙江省乐清经济开发区纬十九路328号
 电话: 0577-6273 5555 传真: 0577-6272 2963
 官网: www.c-lin.cn E-mail: xl@xinling.com
 技术咨询: 400-8236-775



国家高新技术企业 浙江省知名商号



使用说明书
Products Instructions

HHY14

Float Level Relay

Thank you very much for using the C-Lin Brand Float Level Relay. Please read the instruction manual before use!

02A010Q0