

(1) Set Input Signal Number (Access Method: Press the SET key and enter the password P089)

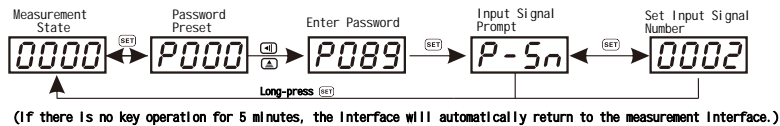

Input Signal Number Table (The input signal number of the transmitter is 0002 at factory):

Input Signal	Input Signal Number	Input Signal Range
AC Voltage	0000	0~500V
	0001	0~100V
AC Current	0002	0~5A
	0003	0~1A

(2) Set Range Display Parameters (Access Method: Press the SET key and enter the password P036)

⑤

(3) Set Transmitter Transduction Parameters (Setting Method: Press the SET key, then enter the password P042)

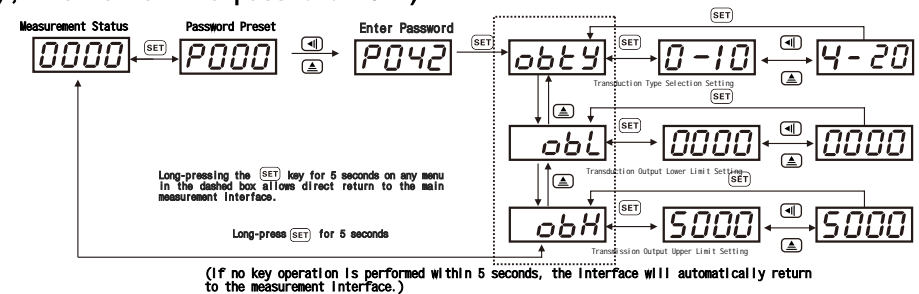

Introduction to the Transmision Parameter Group

Parameter Prompt	Parameter Prompt Description	Setting Range	Factory Default Value	
obty	obty	Transmission Output Type*	4~20;0~20;0~10	4~20
obl	obl	Display Value Corresponding to Transmission Lower Limit*	0~9999	0.000
obh	obh	Display Value Corresponding to Transmission Upper Limit*	0~9999	5.000

*Transmission Output Type selection (obty): Based on transmission output requirements, you can choose 4-20mA, 0-20mA, or 0-10mA.
 *Transmission output lower limit value (obl): The display value corresponding to a transmission output of 0mA or 4mA.
 *Transmission output upper limit value (obh): The display value corresponding to a transmission output of 20mA.
 The resolution varies with the set transmission upper limit; the smaller the upper limit value, the lower the resolution of the transmission output.

Note: This product only provides three current output signals (0-10mA, 0-20mA, or 4-20mA) from the factory. If you need a voltage signal for transmission output, you can either customize it from the manufacturer or connect a 250 resistor by yourself to obtain 1-5V or 0-5V.
 (Note: The accuracy of the shunt resistor directly affects the accuracy of the transmission output voltage.)

⑦

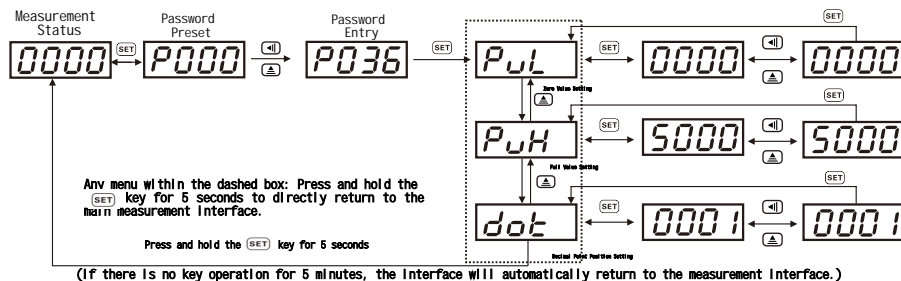

Range Display Parameter Introduction

Parameter Prompt	Parameter Name	Parameter Meaning	Setting Range	Factory Default Value
PvL	PvL	Zero Value*	0000~9999	0.000
PvH	PvH	Full Value*	0000~9999	5.000
dot	dot	Decimal Point Position*	0000~0003	0003

*Zero Value (PvL): The corresponding display value when the input signal is 0, which can be used for zero correction and initial value offset. Normally, this value is set to 0000.
 *Full Value (PvH): The corresponding display value when the input signal reaches the positive maximum. Different full value settings correspond to different resolutions: the smaller the value, the lower the resolution, and the more stable the display.
 *Decimal Point Position (dot): The decimal point position can be set freely.

dot Setting Value	0000	0001	0002	0003
Decimal Point Display Position	0000	000.0	00.00	0.000

⑥

Example of Transmitter Parameter Setting

For instance: To measure the main circuit AC current (0-100A), the current needs to be converted to an AC 0-5A current via a 100/5A current transformer before inputting to the transmitter. If the required transmission output is DC 4-20mA, set the parameters as follows:

- Step 1: Set the input signal number — P-Sn=0002
- Step 2: Set the full range value — PvH=1000
- Step 3: Set the decimal point position — dot=0001
- Step 4: Set the transmission type — obty=4-20mA
- Step 5: Set the display lower limit corresponding to the transmission — obl=000.0
- Step 6: Set the display upper limit corresponding to the transmission — obh=100.0

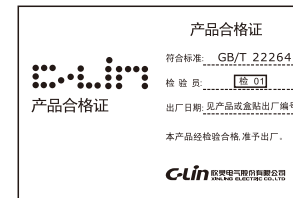

欣灵电气股份有限公司
XINLING ELECTRICAL CO., LTD.

Address: No. 328, 19th Wei Road, Yueqing Economic Development Zone, Zhejiang Province
 Tel: 0577-8273 5555
 Fax: 0577-8273 2963
 Official Website: www.c-lin.cn
 E-mail: c-lin@xlnl.com
 Technical Consultation: 400-8236-776



C-LIN 欣灵电气股份有限公司



使用说明书
Products Instructions

PAS Series

Current-Voltage Transmitter

Thank you very much for using Xinling brand instruments and meters. Please read the instruction manual before using the product!

09A01201

I. Overview

The PAS series current and voltage transmitter (hereinafter referred to as "the transmitter") adopts AC sampling technology to measure electrical quantity parameters (such as current and voltage) in the power grid, and transmits the measurement results in real time. It is widely applied in power consumption scenarios including power automation, intelligent box-type substations, complete cabinets, and distribution stations.

II. Main Features

1. Compact size for easy installation; compatible with 35mm standard DIN rail mounting.
2. Freely configurable transformation ratio, equipped with 4-digit full display and high precision.
3. Multiple isolated signal outputs; the corresponding output current or voltage can be freely set.

III. Model Description

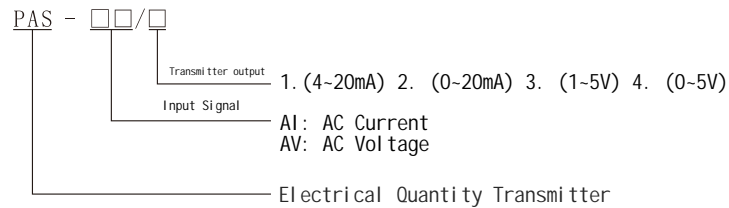

1

V. Outline and Installation Dimensions

Unit: (mm)

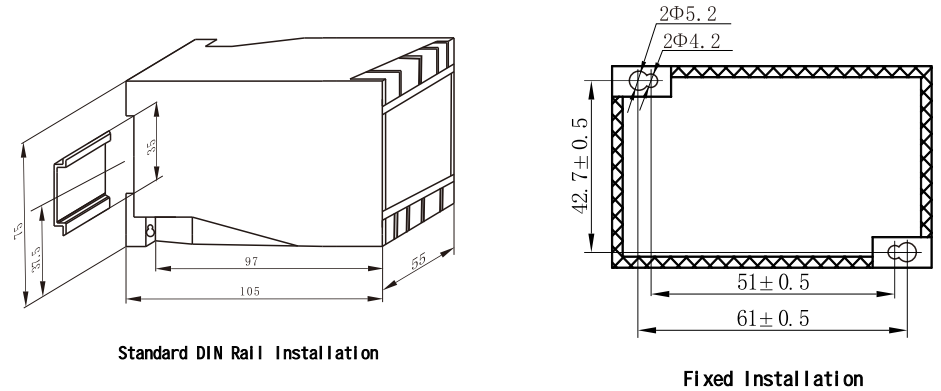

3

IV. Technical Parameters

Performance/Specification		AC Current	DC Current	AC Voltage	DC Voltage	
Input Signal	Input Value	0~5A	0~5A	0~500V	0~500V	
	Overrange	Continuous	1.2 times	1.2 times	1.2 times	1.2 times
		Instantaneous	10 times/5s	10 times/5s	2 times/1s	2 times/1s
	Frequency	50~60Hz	/	50~60Hz	/	
Output	Output Signal	DC4-20(mA), DC0-20(mA), DC1-5(V), DC0-5(V) (customizable for special requirements)				
	Accuracy	0.5 Class				
Power Supply	Range	AC220V±10% 50Hz (customizable for special specifications)				
	Power Consumption	<2VA				
Others	Insulation Strength	2kV 50Hz/1min				
	Ambient Temperature	-10℃~50℃, relative humidity ≤90%				

2

VI. Panel Description

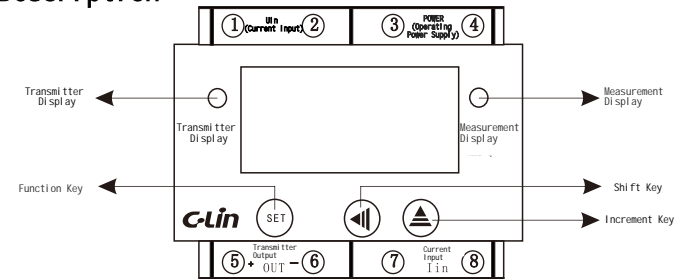

SET: Function Key. When the transmitter displays the measured value, press the SET key to enter programming mode; after completing parameter modification in programming mode, press this key to save the settings, and long-press it for 5 seconds to return to the upper menu.

Speaker icon: Shift Key. 1. Enables left shift of digits; 2. Switches between transmitter display and measurement display in the normal measurement state.

Triangle icon: Increment Key. Enables increment of digital values.

VII. Programming Menu Structure

When using the transmitter, follow the operation flowchart below. It is divided into three items (P089, P036, P042), and operations shall be performed respectively.

4