

Table 8

Rated Current Value (A)	Cable Cross-Sectional Area		Copper Bar Dimensions	
	Quantity	Cross-Sectional Area (mm ²)	Quantity	Dimension (m×m)
500	2	150	2	30×5
630	2	185	2	40×5
700、800	2	240	2	50×5

VII. Use and Maintenance

- All characteristics and accessories of the circuit breaker are set by the manufacturer and must not be adjusted arbitrarily during use.
- The handle of the circuit breaker can be in three positions, indicating the three states of closed, open, and tripped respectively. When the handle is in the tripped position, it should be pulled backward to reset the circuit breaker and then closed.
- Under the condition that the user complies with the storage and use conditions, within 18 months from the date of shipment from the manufacturer, if the circuit breaker is sealed intact and damaged or cannot be used normally due to manufacturing quality issues, the manufacturer is responsible for free replacement and repair.

VIII. Ordering Information

- When placing an order, the product model, rated current, internal components (see Table 5), number of poles, type of protection (distribution protection, motor protection), quantity, etc. should be specified. If no special requirements are specified, our company will supply according to distribution protection and front-plate wiring method uniformly.
For example: Order: XLCM1-225M, 180A, four poles, with undervoltage auxiliary and auxiliary functions, quantity 10 units. The order is expressed as: XLCM1-225M/4370, 10 units.



C-Lin 欣灵 欣灵电气股份有限公司
XINLING ELECTRIC CO., LTD

Address: No. 328, Latitude 19th Road, Yueqing Economic Development Zone, Zhejiang
Hotline: 0577-62735555 Fax: 0577-62722963
Http: //www.xinling.com Email: C-Lin@xinling.com
Technical Service Hotline: 400 1663 188



C-Lin 欣灵

使用说明

Products Instructions

XLCM1L

Series Molded Case Residual Current Circuit Breaker

Thank you very much for using C-Lin Brand Molded Case Residual Current Circuit Breaker. Please read the instruction manual before using the product!

21A002E0

I. Purpose and Usage Instructions

XLCM1 (CM1) Series Molded Case Circuit Breaker (hereinafter referred to as the circuit breaker) is classified into four types based on its rated ultimate short-circuit breaking capacity (Icu): Type C (basic type), Type L (standard type), Type M (higher breaking type), and Type H (high breaking type). This product features small volume, high breaking capacity, short arc distance, and vibration resistance, making it an ideal choice for land and marine applications. Its rated insulation voltage is 800V (500V for XLCM1-63), suitable for AC 50Hz circuits with a rated voltage of 690V and below, used for infrequent circuit switching and infrequent motor starting. The circuit breaker is equipped with overload, short-circuit, and undervoltage protection devices to protect lines and power equipment from damage. It can be installed vertically (upright mounting) or horizontally (horizontal mounting).
Product Standards: Compliant with IEC60947-2 and GB14048.2.

III. Classification of Circuit Breakers

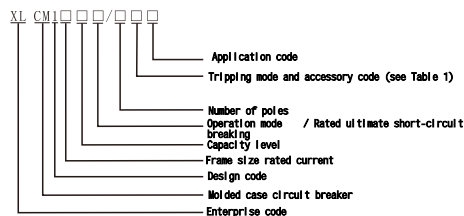

Notes: For distribution circuit breakers, there is no code; for motor protection circuit breakers, it is represented by "2".
For direct handle operation, there is no code; for extended handle, it is represented by "2"; for electric operation, it is represented by "P".

Additional Notes: The 6A specification only has the electromagnetic (instantaneous) type; 2. Specifications with "0" are not recommended.

- Classification by wiring method: front-plate wiring, rear-plate wiring, and plug-in type;
- Classification by overcurrent release type: thermal-magnetic (compound) type and electromagnetic (instantaneous) type;
- Classification by accessory devices: with accessories and without accessories.

Accessory devices are divided into internal devices and external accessory devices, including shunt trip, undervoltage trip, auxiliary contact, and alarm contact. External handles include rotary handle operating mechanism/electric operating mechanism, etc.

II. Operating Environment for Circuit Breakers

- Altitude: Below 2000m;
- Ambient medium temperature: Not higher than +40 (for marine products, not higher than +45) and not lower than -5;
- Resistant to humid air;
- Resistant to salt and oil mist;
- Maximum inclination: 22.5°;
- Reliable operation under normal ship vibration;
- In non-explosive medium, and the medium shall not corrode metals, damage insulation with gases, or contain conductive dust;
- In areas free from rain attack.

Table 5

Model	Overall Dimensions											Mounting Dimensions		
	Front-Plate Wiring									Rear-Plate Wiring				
	W	L	H	W1	L1	H1	H2	H3	L2	H4	H5	A	B	φd
XLCM1-63L	76	135	74	50	170	90.5	28	28	117	44	66	25	117	3.5
XLCM1-63M	76	135	82	50	170	98.5	28	28	117	44	66	25	117	3.5
XLCM1-100L	92	150	68	60	185	86	24	24	132	68	108	30	129	4.5
XLCM1-100M	92	150	86	60	185	104	24	24	132	68	108	30	129	4.5
XLCM1-225L	107	165	86	70	215	110	24	24	144	66	110	35	126	5
XLCM1-225M	107	165	103	70	215	127	24	24	144	66	110	35	126	5
XLCM1-400L	150	257	105	96	357	155	38	38	224	60	120	44	194	7
XLCM1-400M	182	270	110	116	370	160	43	43	234	65	125	58	200	7
XLCM1-630L	182	270	110	116	370	160	43	43	234	65	125	58	200	7
XLCM1-630M	182	270	110	116	370	160	43	43	234	65	125	58	200	7
XLCM1-800L	210	280	106	140	380	145	33	30	234	128	70	243	7.2	
XLCM1-800M														

7. The cross-sectional area of connecting wires and the corresponding rated current are shown in Table 7

Rated Current Value (A)	10	16	32	40	63	80	100	125	160	180	250	315	400
Wire Cross-Sectional Area (mm ²)	1.5	2.5	6	10	16	25	35	50	70	95	120	185	240

VI. Overall and Mounting Dimensions

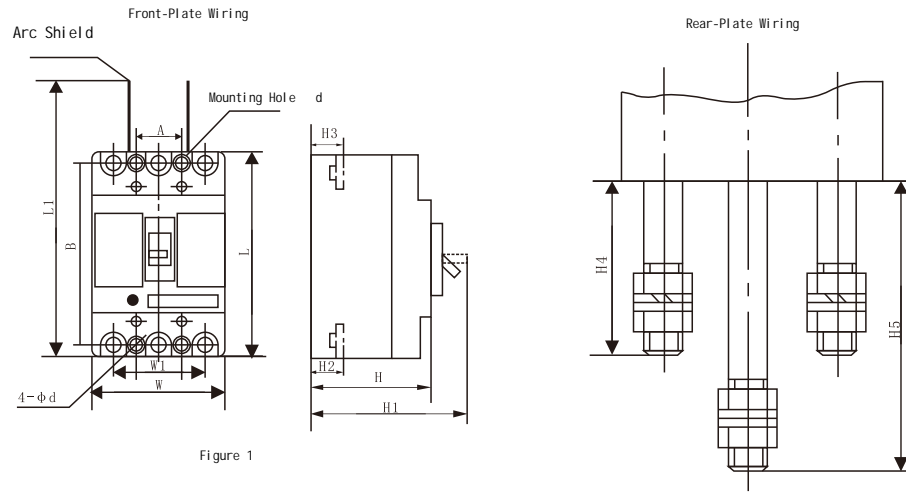

Figure 1

Figure 2

2. The thermal release of the circuit breaker has inverse time-limit characteristics; the magnetic release operates instantaneously. The characteristics are shown in Table 2 (for distribution use).

Table 2

Rated Current of Thermal Release (A)	Inverse Time-Limit Tripping Time For Distribution Protection		Inverse Time-Limit Tripping Time For Motor Protection	
	1.05In (Cold State) No Operation Time (h)	1.30In (Hot State) Operation Time (h)	1.05In (Cold State) No Operation Time (h)	1.20In (Hot State) Operation Time (h)
$10 \leq I_n \leq 63$	1	1	2	2
$I_n > 63$	2	2	2	2

Note: The inverse time-limit characteristics of the circuit breaker should be tested within the ambient temperature range of 5 ~40.

3. The magnetic release characteristics (short-circuit protection) of the circuit breaker are shown in Table 3.

Table 3

Protection Type	Protection Type	Protection Type
Rated Current Setting Range	$10I_n \pm 20\%$	$12I_n \pm 20\%$
	2	

V. Technical Data of Accessory Devices

The rated values of auxiliary contacts and alarm contacts are shown in Table 4.

Table 4

Classification	Frame Size Rated Current (A)	Conventional Heating Current 1th (A)	Rated Operating Current Ie (A) at AC 380V
Auxiliary Contact	≤ 225	3	0.30
	> 225	6	1
Alarm Contact	≤ 400	AC 220V 1A	—

IV. Technical Reference

1. Circuit Breaker Model Specifications and Breaking Capacity are shown in Table 1

Table 1

Model	Frame Size Current Inm (A)	Rated Current In (A)	Rated Operating Voltage Un	Rated Insulation Voltage Ui (V)	Rated Ultimate Short-Circuit Breaking Capacity Icu (kA)	Number of Poles	Arc Distance (mm)
XLCM1-63L	63	6, 10, 16, 20, 32, 40, 50, 63	400	500	15	3	≤ 50
XLCM1-63M					25	3, 4	
XLCM1-100L	100	63, 80, 100	400	690	35	3	≤ 50
XLCM1-100M					50	3, 4	
XLCM1-225L	225	100, 125, 160, 180, 200, 225	400, 690	690	35	3, 4	≤ 50
XLCM1-225M			240, 400		50	3, 4	
XLCM1-400L	400	225, 315, 350, 400	400, 690	690	50	3, 4	≤ 100
XLCM1-400M			65		3, 4		
XLCM1-630L	630	400, 500, 630	400, 690	690	50	3, 4	≤ 100
XLCM1-630M			65		3, 4		
XLCM1-800M	800	630, 700, 800	400, 690	800	100	3, 4	≤ 100

Note: Parameters marked with "*" are tested at 400V, and the 6A specification does not have overload protection function.

2. When the applied voltage of the shunt trip is between 85% and 110% of the rated control power supply, it can reliably trip the circuit breaker.
 3. When the power supply drops to the range of 35% to 70% of the rated operating voltage of the undervoltage trip, the undervoltage trip can reliably trip the circuit breaker; when the power supply voltage is lower than 35% of the rated operating voltage of the undervoltage trip, the undervoltage trip can prevent the circuit breaker from closing; when the power supply voltage is higher than 85% of the rated operating power supply voltage of the undervoltage trip, the undervoltage trip can ensure the circuit breaker closes reliably.

Table 5. Trip Unit Modes and Accessory Codes

Trip Unit Type	Accessory Name														
	None	Alarm Contact	Shunt Trip	Auxiliary Contact	Undervoltage Trip	Shunt Trip Auxiliary Contact	Shunt Trip with Undervoltage Trip	Two Sets of Auxiliary Contacts	Auxiliary Contact with Undervoltage Trip	Shunt Trip with Alarm Contact	Auxiliary Contact with Alarm Contact	Undervoltage Trip with Alarm Contact	Shunt Trip Auxiliary Contact with Alarm Contact	Two Sets of Auxiliary Contacts with Alarm Contact	Auxiliary Contact with Undervoltage Trip and Alarm Contact
Instantaneous Trip Unit	200	200	200	200	200	200	200	200	200	200	200	200	200	200	200
Compound Trip Unit	200	200	200	200	200	200	200	200	200	200	200	200	200	200	200