

Dual Power Automatic Transfer Switch

XLDS3 Series

Clin 欣灵电气



Application

XLDS3 Series PC class dual power Auto transfer switch, mainly used in two way power supply system with rated voltage below 400V, AC 50/60Hz, rated current up to 630A, when one power supply abnormal, then it transfer between two power supply system, to ensure the power supply reliability and safety.

The ATS have "Main Power", "Backup Power" and "Two way OFF" positions, with higher breaking and making capacity, it not only can meet normal load transfer, but also can meet high inductive impedance or big motor load transfer, meanwhile due to have high short time withstand current capacity, no need special SPCD, doesn't affect the selective of inside circuit, meanwhile it also can meet the application at big capacity power supply side.

Product confirm to GB/T14048.11 《Low voltage switch equipment and control equipment Part 6-1: multi-functional transfer switch equipment》 Standard.

Model Meanings

XL DS 3 -125 C 4P
① ② ③ ④ ⑤ ⑥

①	Company code
②	PC class auto transfer switch equipment
③	Design code
④	Rated working current
⑤	Controller type A: Basic type Single phase monitor B: Standard type three phase monitor+fire-fighting ,generator control C: Intelligent type three phase monitor+fire-fighting,generator control+LCD display D: Intelligent type three phase monitor+fire-fighting,generator control+split LCD display
6	Poles (3P,4P)

Working Conditions

- Ambient temperature: $-20^{\circ}\text{C} \sim +40^{\circ}\text{C}$; 24 hours average not more than $+35^{\circ}\text{C}$;
- Atmospheric conditions: humidity not more than 50% at max. $+40^{\circ}\text{C}$, higher humidity is allowed at lower temperature, at most wet month, the average max humidity is 90% at the average min temperature $+25^{\circ}\text{C}$, and have considered the condensation on the product surface due to temperature variation;
- Altitude: Not more than 2000m;
- Pollution Class: The installation site environment pollution Class 3.

XLDS3 Series

Technical Data

Type	RDS3-125	RDS3-250	RDS3-630
Poles	3/4	3/4	3/4
Rated Working current (A)Ie	16-125	140-250	315-630
Rated working voltage (V)Ue	400	400	400
Rated insulation voltage (V)Ui	800	800	800
Rated impulse withstand voltage(KV)Uimp	8	8	8
Use category	AC-33B	AC-33B	AC-33B
Rated short time withstand current(KA,rms)Icw	10kA(200mS)	10kA(200mS)	25kA(200mS)
Rated short circuit Making capacity (KA peak)Icm	20kA	30kA	50kA
Rated limit short circuit current (KA)Iq	120kA	120kA	120kA
Rated control power supply voltage(V)Us	230V/50Hz	230V/50Hz	230V/50Hz
Contact transfer time(s)	1.5	1.8	2
Operation cycles	no electricify	8500	7000
	with electricify	1500	1000
	Total	10000	8000
Outline size(mm)WxDxH	245×130×122	295×175×175	430×272×228
Weight (kg)	5	10	20

ATS Functions List

Type	A type controller	B type controller	C type controller	D type controller
Control power voltage	AC 230V/50Hz			
Auto transfer	Auto transfer and auto recovery	Auto transfer auto recovery, auto transfer no auto recovery, power grid-generator		
Manual transfer	Manual main power, manual backup power, manual OFF			
Isolation lock	Off position have isolation function, also can padlock locked			
Generator control		Generator start and stop		
Fire linkage		with passive fire linkage signal to switch OFF the device, with one set passive NO feedback contact		
Display mode	Mechanical indication:device ON/OFF status, operating mode LED:device ON/OFF status, power status		Mechanical indication:device ON/OFF status, operating mode LED:device ON/OFF status, power status LCD:device ON/OFF status, power status, data setting	
Setting mode			Key-press operation, Chinese/English display interface, can set the working mode, low-voltage value, over-voltage value, delay time, auto transfer mode etc.	
Power monitoring	A phase voltage missing monitor	ABC three phase over-voltage 265V ABC three phase low-voltage 187V ABC three phase voltage missing monitor	ABC three phase over-voltage (240-290V adjustable) ABC three phase low-voltage (150-200V adjustable)	ABC three phase voltage missing monitor
Delay time			Transfer delay (0-300s adjustable) Recovery delay (0-300s adjustable) Generator start, stop delay (0-300s adjustable)	
Mounting mode	Integrated mounting			Split mounting

Note: B type controller if need auto transfer no recovery mode, please specify when ordering.

Dual Power Automatic Transfer Switch

XLDS3 Series

Product Structure

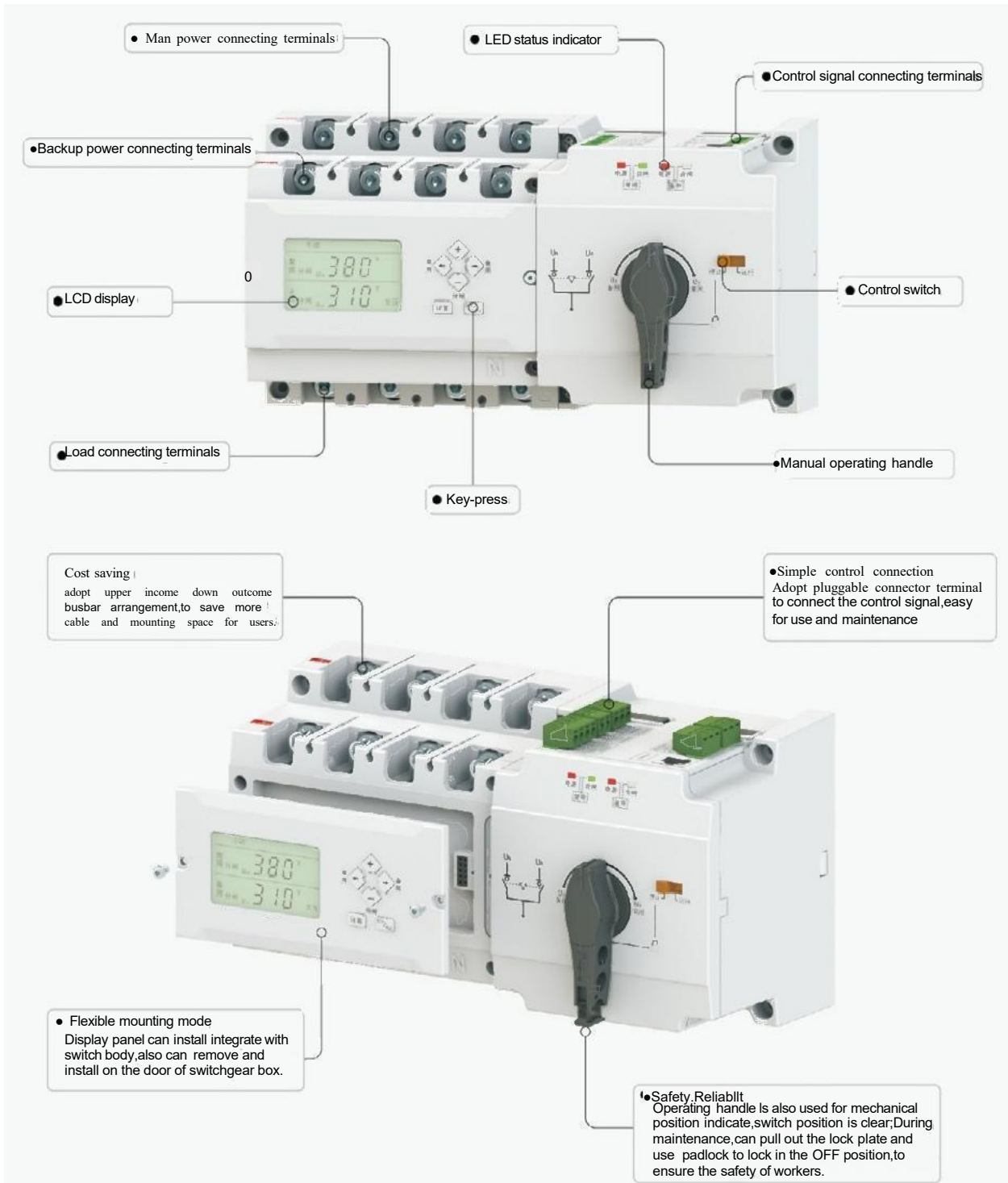

XLDS3 Series

Product Features

- High short time withstand capacity,high short circuit making capacity
Adopt high density silver alloy contact,can withstand thousands operating cycles and no burning loss,no pit or no melting.No need daily contact maintenance,100%rated current continues load.Contact system adopt bridge type double break rotating insert structure,reach high short time withstand capacity and high short circuit making capacity,no need special SCPO,no affect the selective of circuit,meanwhile also can meet the application in the big capacity power supply system.
- 10le making and breaking capacity,match the AC-33B use category
Optimized magnetic blow-out arc extinguish system,easily reach 10le making and breaking capacity,match AC-33B use category and also match the load property of AC typical application of GB/T 14048.11 standard,have wide application range.
- Stacking structure,small volume
Main,backup power switch part adopt modularize design,stacking arrangement,make the product volume more smaller than other similar products.
- Three position with isolation lock
With“Main power position”,“OFF position”,“Backup power position”three working position,can used for fire linkage and high inductive impedance load;OFF position with isolation lock function,can meet the isolation requirement during th load side maintenance.
- Display controller can integrated installation,also can split installation
Display controller and transfer controller split set up,display controller can install on the switch body panel(Integrated type),also can install separately on the door panel of switchgear box(split type),convenient for user to check and control of the ATS status.
- Multi-functions,different modes
Controller have under-voltage,over-voltage,phase missing automatic transfer function and motor-driven forced transfer function,Auto mode have auto transfer with auto recovery and auto transfer without recovery two modes,to fit with different location;Have fire linkage function,to cutoff the load power under emergency situation.

Controller Functions

- Under-voltage detection
Controller makes under-voltage detection for main power and backup power,when the under-voltage is detected with the power supply,it will start the auto transfer function to transfer to another power supply.When the power supply voltage is detected recovered to acceptable range(Recovery value),controller will decide whether make transfer according to the setted transfer mode and also can set transfer delay time.
- Over-voltage detection
Controller makes over-voltage detection for main power and backup power,when the over-voltage is detected with the power supply,it will start the auto transfer function to transfer to another power supply.When the power supply voltage is detected recovered to acceptable range(Recovery value),controller will decide whether make transfer according to setted transfer mode and also can set transfer delay time.
- Transfer delay
When the main power is confirmed abnormal and backup normal,transfer delay start delay counting,after time delay is over then transfer from the main power to backup power.This time delay can wait to confirm whether the main power is short time abnormal,also can avoid switch frequently transfer.
- Recovery delay
Recovery delay is after backup power supply,and main power is confirmed available,then start delay counting,when delay time is over then transfer from the backup power to main power.This delay time can wait the main power supply output stable before it supply to the load.
- Generator start delay
Generator start delay can avoid starting genset due to short time power of.When main power fault then start delay counting,and after the delay time is over then send generator start signal.
(Note:when the main power suddenly cutoff and genset didn't start,under this situation it can't delay due to no power supply to the controller,if need to use this function have to connect a DC24V aux.power supply to the controller to achieve the time delay function)
- Generator stop delay
Generator stop delay can remain the generator in hot backup status after it stop power supply to the load,avoid the genset restarting due to main power in short time recovery.When transfer from the backup power to main power supply then start the delay counting,after delay time counting is over then controller send genset stop signal.

Dual Power Automatic Transfer Switch

XLDS3 Series

- Transfer mode

Controller provides different transfer mode function according to the power supply property

1:Power grid -Power grid:

At the application of power grid -power grid,ATS can provide auto transfer with auto recovery and auto transfer no auto recovery two transfer mode

Power grid -power grid auto transfer with auto recovery mode

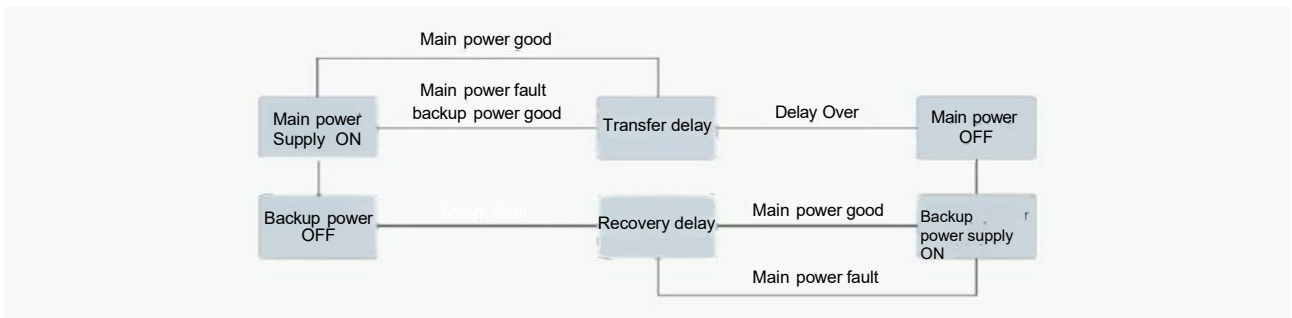

Power grid -power grid auto transfer no auto recovery mode

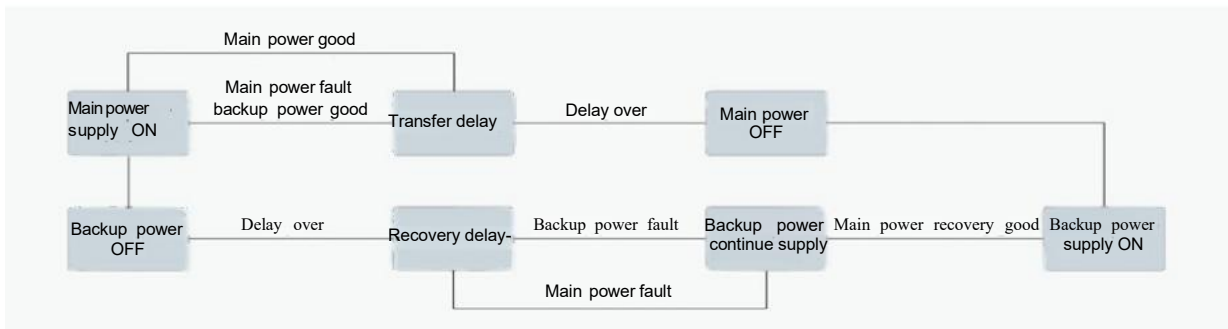

2:Power grid-generator mode

Transfer between power grid -generator

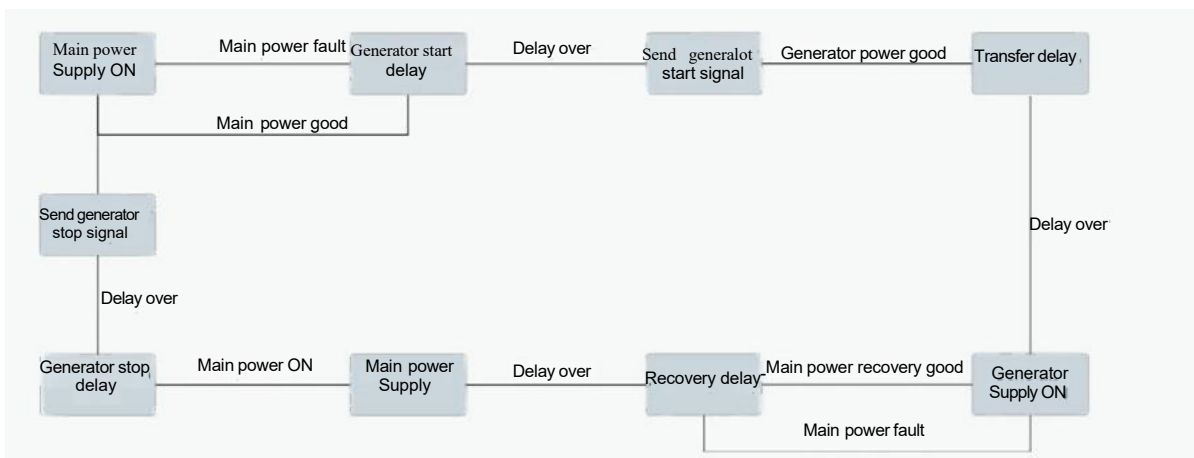

XLDS3 Series

Display Panel

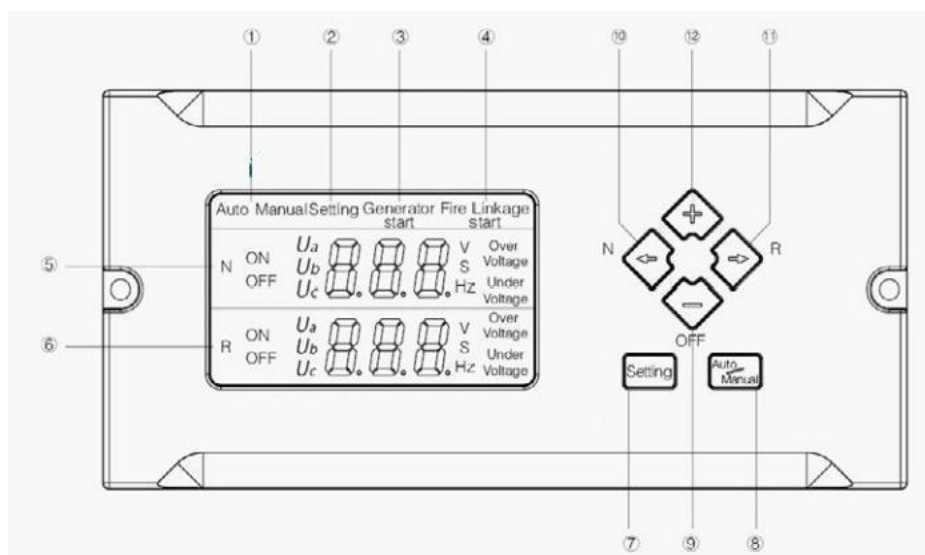

- 1:Auto, Manual working mode indicate;
- 2:Setting status indication;
- 3:Generator start signal indicate;
- 4:Fire linkage function start indicate;
- 5:Main power status data indication zone:during working status display main power voltage data and transfer delay time, during setting status display setting item code;
- 6:Backup power status data indication zone:during working status display backup power voltage data and recovery delay time,during setting status display setting item code;
- 7:Setting button:press this button will enter into controller setting menu;
- 8:Auto/Manual transfer mode selection button:under working status it used to select the Auto and Manual transfer mode, under the setting status it used as save and escape function;
- 9:Trip button:under manual control mode if any one of the two power is good,push this button will change to OFF position;under setting status it is used for data decrease button;
- 10:Main power transfer button:under manual control mode and main power good,push this button will forced to transfer to main power;Under setting status,it used for up page button;
- 11:Backup power transfer button:under manual control mode and backup power good,push this button will forced to transfer to backup power;Under setting status,it used for down page button;
- 12:+Button:under setting status this button is used as data increase button;

Dual Power Automatic Transfer Switch

XLDS3 Series

Outline And Mounting Size (mm)

- XLDS3-125(3P,4P outline and mounting size same)

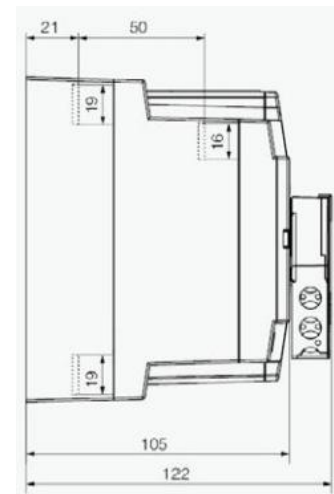
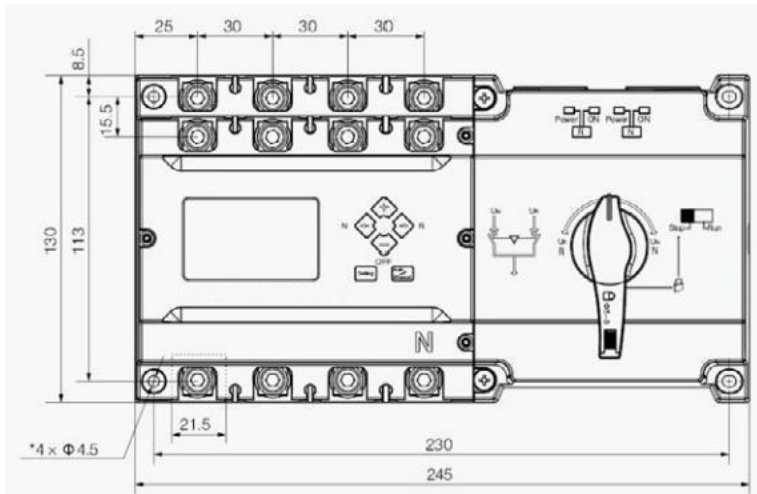

- XLDS3-250(3P,4P outline and mounting size same)

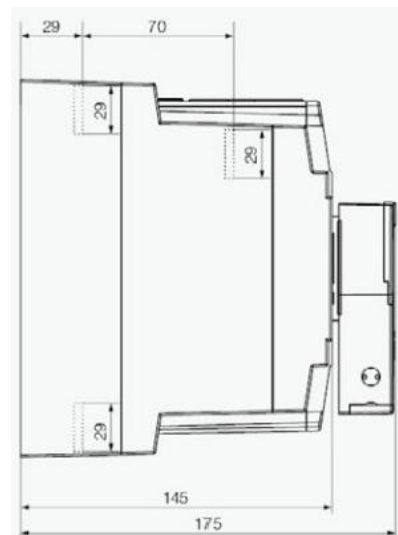
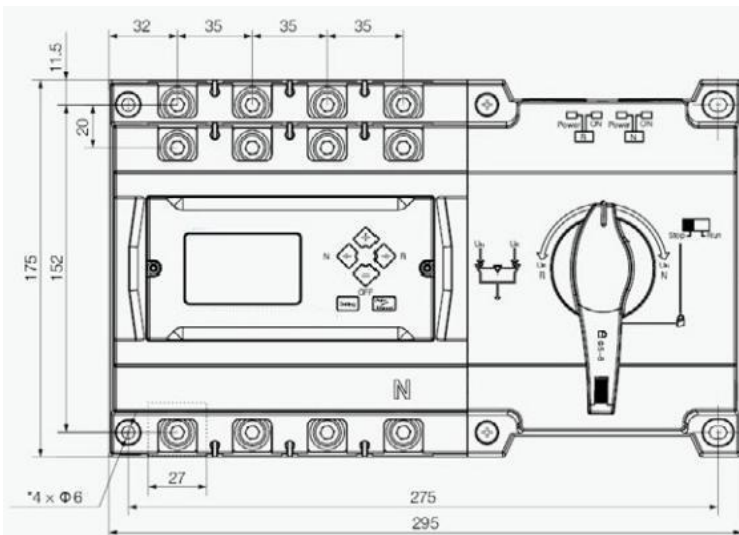

XLDS3 Series

Outline And Mounting Size (mm)

- XLDS3-630 (3P,4P outline and mounting size same)

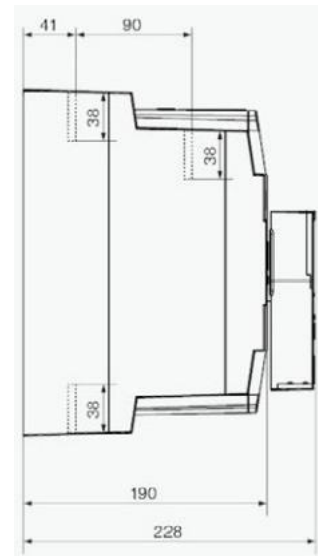
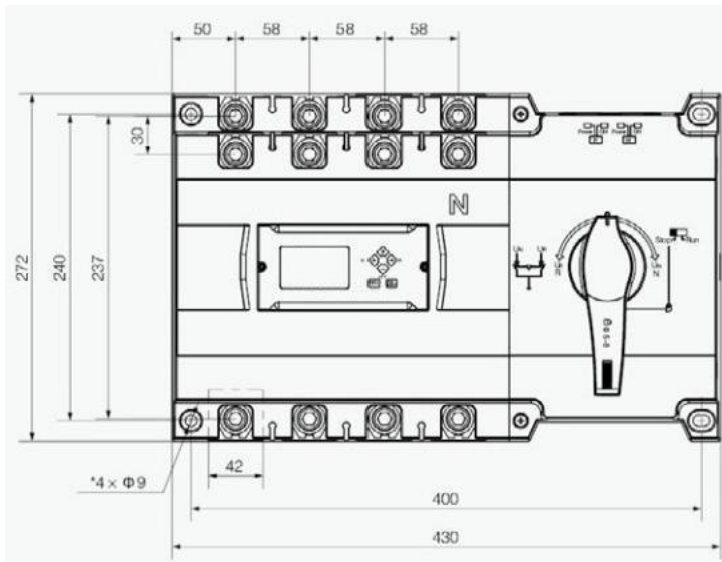

- Display controller outline and split mounting hole size

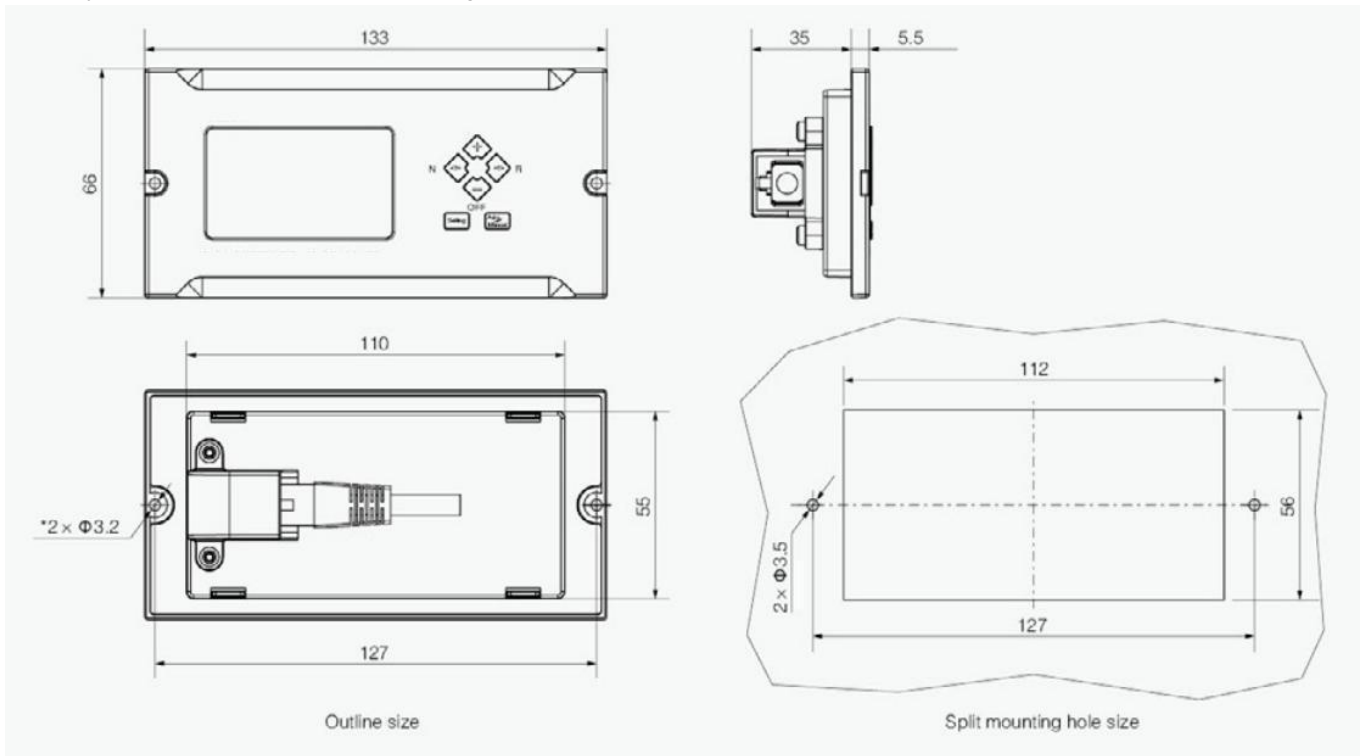

Dual Power Automatic Transfer Switch

XLDS3 Series

Controller Terminal And Wiring Instruction

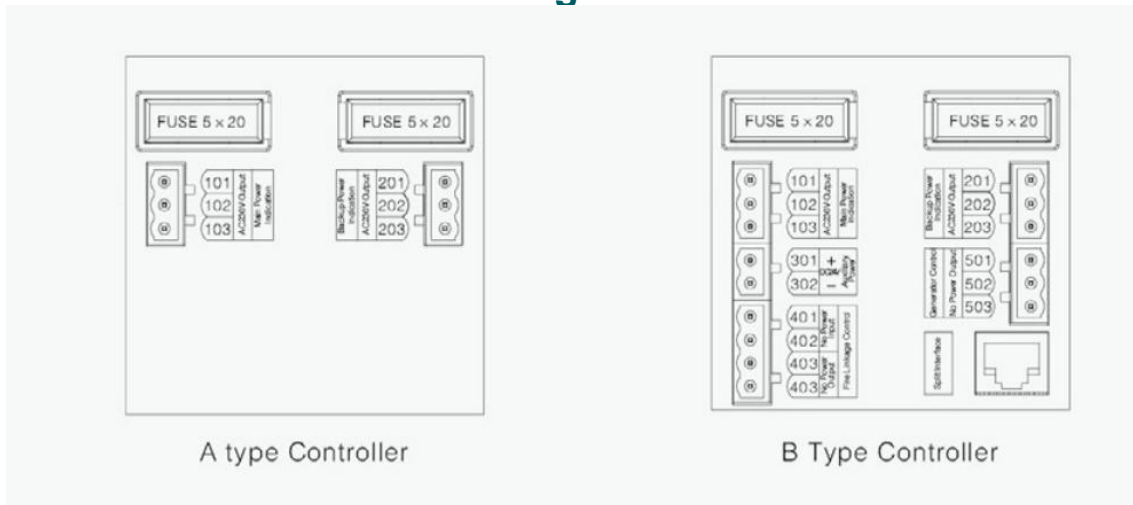

- 101~103 main power external indicator signal(Active AC230V/0.5A)

101-Indicator common null line 102-Main power indicator signal output 103-Main power ON signal output

- 201~203 Backup power external indicator signal(Active AC230V/0.5A)

201-Indicator common null line 202-Backup power indicator signal output 203-Backup power ON signal output

- 301~302 aux.power input (DC15V-24V/0.5A)

The purpose to put an aux.power is to control the generator start delay time under the Power grid-Generator mode,if without aux.power,the generator start delay time is 0s,if the generator start delay function not needed,then no need to connect the aux.power.

- 401~404 Fire linkage control terminals

401,402 Fire linkage control signal input,this terminal external only can connect to a set of NO passive contact (if the signal from fire-fighting equipment is an active signal,must first connect through a small relay.then connect the relay NO point to controller)after NO contact closed ATS immediately transfer to OFF position and cutoff the power supply.

403,404 Inside is a set of NO relay contact point,used for sending the fire-fighting movement signal back;when it is normal,the contact is NO status,when there is fire-fighting signal input to the controller,and the switch transfer to OFF position,the 403 and 404 closed.(Notes:when the fire linkage function is active,the ATS will stop working,if want the ATS to working again,must first clear up the fire-fighting signal and then switching the Auto/Manual control switch one time,the ATS will recovery normal working)

- 501~503:Generator start control signal output

When the backup power is Auto start generator,users can connecting the 501~503 terminals to the generator controller to achieve the generator auto start function,inside 501~503 terminal,is a set of passive relay contact point,502 is the relay common terminal,503 is relay NC point,501 is relay NO point;

Under power grid-generator mode and auto transfer mode,when main power normal,502 and 501 is closed,502 and 503 open,if main power failure and backup power no power,502 and 503 closed after generator start delay time, meanwhile 502 and 501 open to send generator start signal,after generator start successfully ATS auto transfer to backup power supply,if main power recovery good,then controller after recovery delay time to control the switch transfer to main power supply,after main power ON,502 and 501 closed after generator stop delay time,502 and 503 open to send generator stop signal.

XLDS3 Series

3P Product Wiring

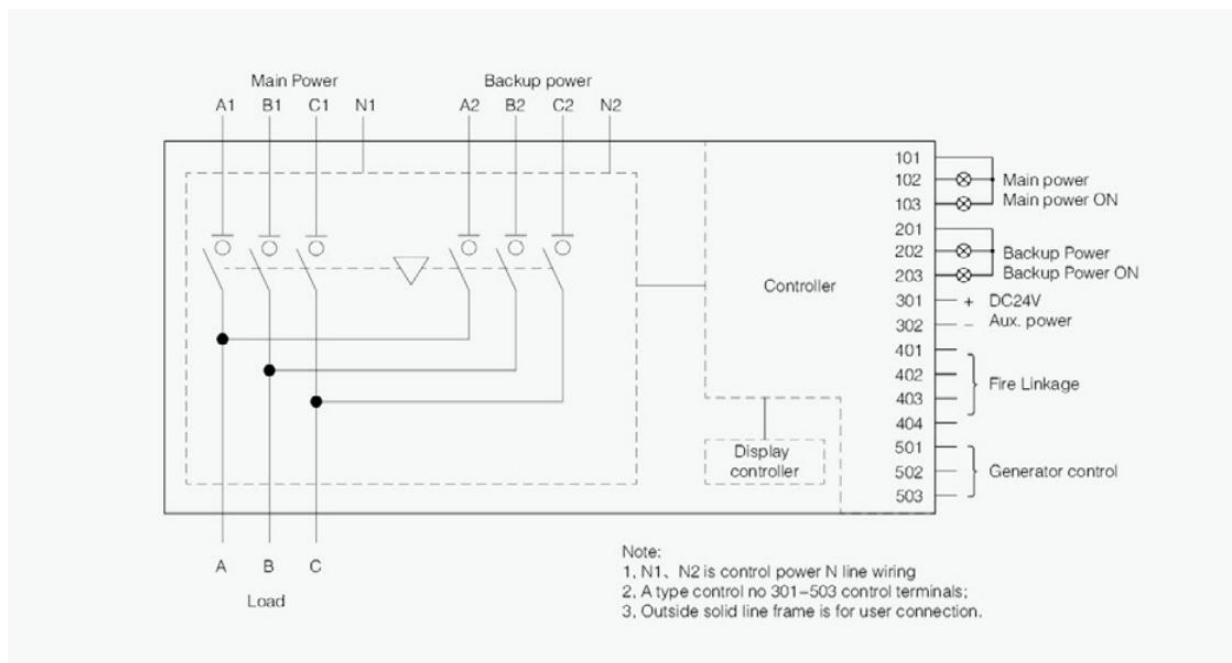

4P Product Wiring

