

I. Overview

The XMT series temperature display and control instrument (referred to as the instrument) is designed with a single - chip microcomputer as the core and produced using SMT chip - mounting technology. The whole machine has advanced technology and stable performance, and has advantages such as accurate temperature control, strong anti - interference ability, and simple operation. The LED window of the instrument can display the measured value and set value respectively. With fully digital adjustment and automatic cold - end compensation for thermocouples, it can meet different usage requirements. The product is widely applied to temperature measurement and control in industries such as packaging machinery, food machinery, woodworking machinery, metallurgy, and ceramics.

This series of instruments complies with the standard GB/T13639.

II. Main Technical Parameters

1. Display error: $\pm(1.0\%FS + 1 \text{ digit})$.
2. Cold - end compensation error: ± 2 .
3. Control sensitivity: 0.75%FS.
4. Instrument resolution: 1 or 0.1 .
5. Instrument sampling period: 3 times/s.
6. Output contact capacity: Relay contact 220V resistive load 3A; Relay contact 220V inductive load 1A.
7. Output DC voltage: SSR drive level DC12V \pm 2V (30mA).
8. Time - proportion regulation: Output period 20s.
9. Signal input: Thermocouple: K or E; RTD: Pt100 or Cu50.
10. Control mode: Two - position, time - proportion.
11. Working power supply: AC220V \pm 10% 50Hz~60Hz (special power supply can be customized).
12. Working environment: Temperature 0~50 (non - freezing state), relative humidity 85%, in an environment without corrosive gas.
13. Atmospheric pressure: 86kPa~106kPa.

①

III. Instrument Model Definition

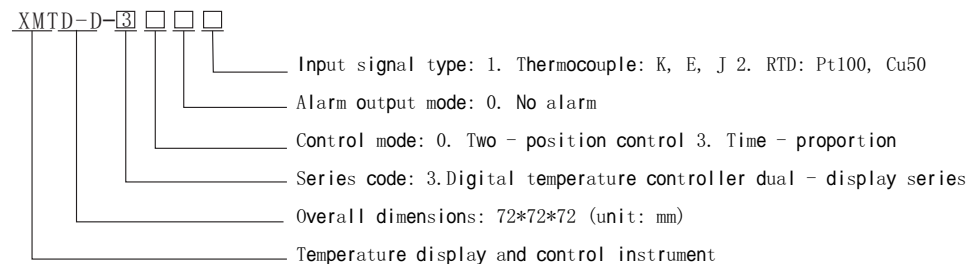
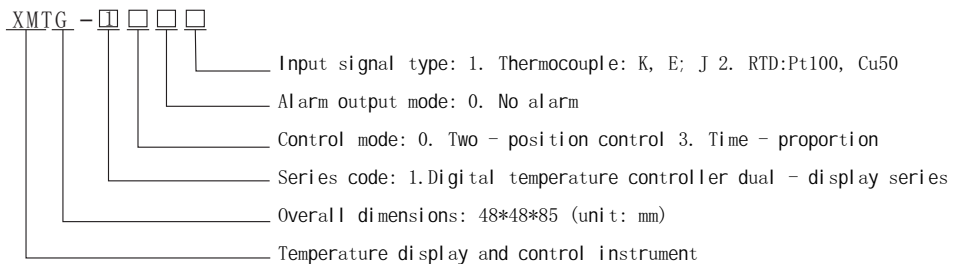

②

IV. Front Structure of the Instrument (Typical Explanation)

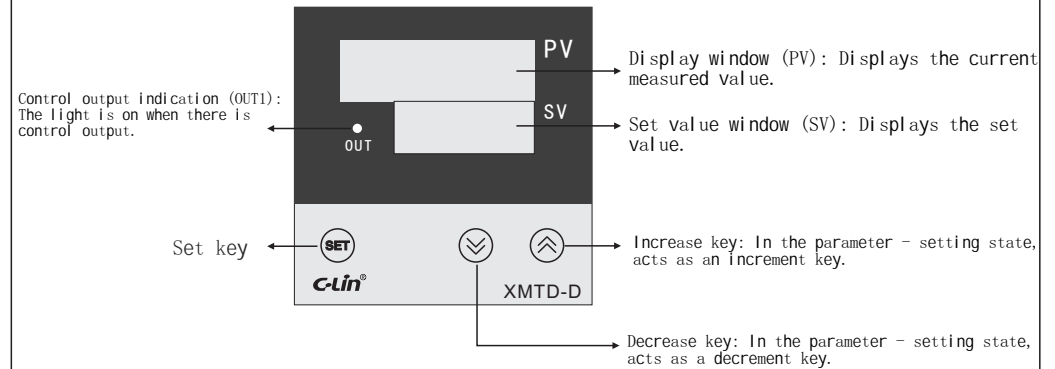

③

V. Instrument Operation Instructions

After the instrument is correctly wired according to the wiring diagram and powered on, the PV window of the instrument displays the Xinling trademark and sensor type, and the SV window displays the version number and output mode. Finally, the PV window of the instrument displays the current measured value, and the SV window displays the current set value. **Press the increase key and decrease key to modify the set value in the SV window.**

VI. Instrument Working Mode Instructions

1. Two - position control: When the measured value is lower than the set temperature, the instrument terminal is always low - connected, and the control output indicator light (OUT) is on; when the actual temperature is higher than the set temperature, the instrument terminal is always low - disconnected, and the control output indicator light (OUT) is off. When first powered on, first set the set value to 80% of the required temperature. After the instrument switches several times, then set the set value to the required temperature. This can reduce the temperature overshoot when first powered on.
2. Time - proportion: When the measured value does not enter the proportion band, the instrument relay is always low - connected, and the load heats up. After entering the proportion band, the relay starts to perform switching actions regularly. The closer the temperature is to the set temperature, the shorter the time of being always low - connected, and vice versa. This instrument changes the temperature by altering the average heating power of the load. Therefore, when heat dissipation and heating are balanced, the temperature can basically stabilize within a very small range.

④

VII. Sensor Instructions for Use

	Material Composition	Graduation Number	Instrument Measurement Range		Material Composition	Graduation Number	Instrument Measurement Range
Thermocouple	Nickel Chromium Copper Nickel	E	0~800	Resistance Temperature Detector	Copper	Cu50	-19.9 ~150
	Nickel Chromium Nickel Silicon	K	0~999		Platinum	Pt100	-100 ~500 -19.9℃~99.9℃

a) Thermocouple: The positive and negative poles show a short-circuit state when measured with a multimeter. For each 1 change in temperature, the signal between the positive and negative poles of the K-type sensor changes by approximately 0.04mV, and that of the E-type sensor changes by approximately 0.063mV.
b) RTD: For the Cu50-type sensor, the two black wires are in a short-circuit state. When the ambient temperature is 0, the resistance between the red wire and the black wire is 50Ω. For each 1 change in temperature, the resistance changes by approximately 0.21Ω. For the Pt100-type sensor, the two black wires are in a short-circuit state. When the ambient temperature is 0, the resistance between the red wire and the black wire is 100Ω (standard value). For each 1 change in temperature, the resistance changes by approximately 0.38Ω.

VIII. Wiring Diagram of Improved Products

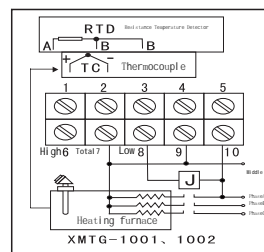
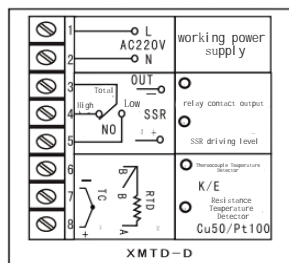

⑤

Code Information	Fault Cause Description	Troubleshooting Method
LLLL	Measured temperature is below the lower limit of the range or the sensor wire is connected reversely	Check the sensor
HHHH	Measured temperature is above the upper limit of the range or the sensor is disconnected	Check the sensor

If the sensor is disconnected, the digital tube window may briefly display "LLLLL" and will eventually show "HHHHH".

3. The connection of the RTD to the instrument should use a three-wire system. When connecting, ensure that the thickness, length, and other parameters of each extension wire are identical.

X. Ordering Instructions

Please specify the product model, graduation number, measurement range, working power supply, and order quantity.

For example: XMTG - 1001, K, full range, AC220V, 5 units.

⑦

Note 1: "High, Total" represents a set of passive normally-closed contacts of the output relay inside the instrument, and "Total, Low" represents a set of passive normally-open contacts of the output relay inside the instrument. "Neutral" represents the neutral wire of the instrument's working power supply, and "Phase" represents the live wire of the instrument's working power supply.

Note 2: Subject to the diagram attached to the instrument housing. If there is any change, no further notice will be given.

Peripheral Wiring Diagram

Name	Physical Diagram	Others
Thermocouple TC		When wiring the thermocouple (TC), the red terminal of the sensor is connected to "+", and the blue terminal of the sensor is connected to "-".
Resistance Temperature Detector RTD		When wiring the RTD (Resistance Temperature Detector), the two black terminals of the sensor are connected to "B, B" of the instrument, and the red terminal of the sensor is connected to "A".
AC Contactor		The coil of the AC contactor is the working power supply of the AC contactor. "A1" and "A2" are the coil terminals.

IX. Maintenance and Precautions of the Instrument

To ensure accurate measurement and long-term reliable operation of the instrument, the following must be noted:

1. When connecting the thermocouple to the instrument, the corresponding type of compensation wire must be used. Be sure to use the specified compensation wire. If ordinary extension wires or compensation wires are connected with positive and negative poles reversed, errors will occur. The red color of the compensation wire indicates the "+" pole, and the blue (black or white) color indicates the "-" pole.
2. Fault code prompt:

⑥



C-Lin
欣灵电气股份有限公司
XINLING ELECTRICAL CO., LTD.
地址: 浙江省乐清经济开发区纬十九路328号
电话: 0577-6273 5555 传真: 0577-6272 2963
Http://www.c-lin.cn E-mail: xl@xinling.com
技术咨询: 0577-6273 1220



国家高新技术企业 浙江专精特新企业

C-Lin 欣灵

使用说明书
Products Instructions

XMTD - D / XMTG - 1000 Improved
Temperature Display and Control Instrument

Thank you very much for using C-Lin brand temperature control instrument. Please read the instruction manual before using the product!

09A024E0