



**C-Lin**  
欣灵电气股份有限公司  
XINLING ELECTRICAL CO., LTD.  
地址：浙江省乐清经济开发区纬十九路328号  
电话：0577-62735555 传真：0577-62722963  
官网：www.c-lin.cn 邮箱：xl@xinling.com  
技术咨询：400-8236-775



## ZN48/ZN72 Counting Relay

Thank you for using C-Lin Counting Relay, please kindly read the manual before using the product.

29A079P1

### Content

- 1. Product description ..... 1
- 2. Function A  
Single Setting Dual digital 4-digit Time Relay ..... 6
- 3. Function B  
Double Setting Dual Digital 4-digit Time Relay ..... 7
- 4. Function C  
Single Setting 8-digit digital Display Timer ..... 8
- 5. Function D  
Single Setting dual digital display 4-digit Frequency Meter ..... 9
- 6. Function E  
Single Setting Digital Counting/Meter Relay ..... 11
- 7. Order Information ..... 13

#### A. Introduction

ZN48/ZN72 counting relay is a multifunctional combination product, they are only different in shape and terminal arrangement. It can be switched to time relay, totalizer, frequency/tachometer, counting/meter counter by setting. This product has many working modes, which are widely used in many industries, such as military, textile, chemical, cement, and so on. This product meets the requirements of GB/T 14048.5..50

#### B. Technical Parameters

1. Working voltage (power supply voltage): AC380V, AC/DC100~240V, AC/DC24V/50Hz, the permissible voltage fluctuation range of (85%~110%) Ue.
- 2.Ue/Ie: use the category under each rated operating voltage Ue/Rated operating current Ie:AC-15 Ue:AC250V, Ie:3A.
3. Contact capacity: 3A AC250V (resistive)
- 4.Rated impact withstand voltage Uimp:2.5KV
- 5.Rated insulation voltage Ui:400V
6. Conventional heating current Ith:5A
7. Pollution level: 3
8. Protection level: front panel IP40
- 9.Ambient Temperature:-5 ~+40
- 10.Relative humidity:≤90%.
- 11.Altitude: ≤2000m
- 12.Installation:Panel type

#### C.Wiring Diagram

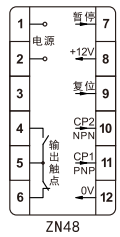

#### ZN48 Wiring instructions

- [1], [2] for the power input (not distinguish polarity)
- [4], [5] for a group of normally open (NO) contacts
- [5], [6] for a group of normally closed (NC) contacts
- [7] is a Pause terminal
- [8] for the DC12V 30mA (max) sensor auxiliary power output
- [9] is a Reset terminal
- [10] is the CP2 signal input (NPN sensor)
- [11] is the CP1 signal input (PNP sensor)
- [12] is 0V (common terminal)



#### ZN72 Wiring Instructions

- [1], [2] for the power input (not distinguish polarity)
- [7], [8] for a group of normally open(NO) contacts
- [8], [9] for a group of normally closed(NC) contacts
- [10] is a Pause terminal
- [11] for the DC12V 30mA (max) sensor auxiliary power outputs
- [12] is a Reset terminal
- [16] is the CP2 signal input (NPN sensor)
- [17] is CP1 signal input (PNP sensor)
- [18] is 0V (common terminal)

#### D. Mounting Dimensions

Mounting Hole Size: ZN48=45<sup>+0.5</sup> × 45<sup>+0.5</sup> mm; ZN72=68<sup>+0.5</sup> × 68<sup>+0.5</sup> mm

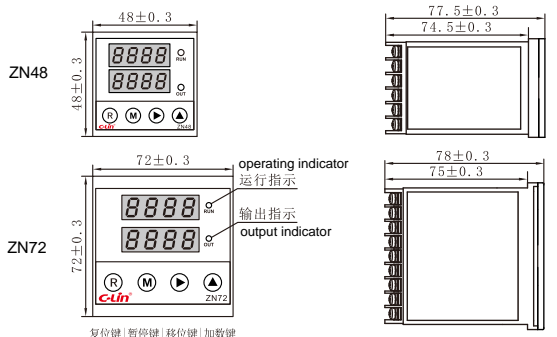

#### E. Function Setting

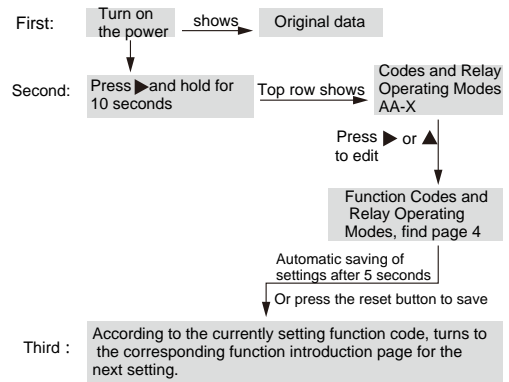

Press the Shift key for 10 seconds, when the upper digital row displays " AA-X ", it will enter the function setting state. The first two AA is the function code, and the last one X is the relay operating mode. Use the Shift key to select the digital tube to make it blink, and use the Add key to change the parameter value. The setting will be saved automatically after 5 seconds, or press the reset key to save. Note: The setting should be done continuously throughout the setting process, and each step should not exceed 5 seconds, otherwise the setting will be saved and exited automatically. Subsequently press the reset key, it will run with the newly set parameters.

**Description:**

AA is the function code, 16 kinds of functions find the table on page 5, X is the relay operating mode. Each function supports different working modes, selecting the wrong operating mode may not work properly.

The 6 modes have the following meanings.

- X=1**, work after energizing, relay will be engaged when it reaches the set value.
- X=2**, not work after energized (press reset button or short connect reset terminal and 0V to work), the relay will be engaged when reaching the set value.
- X=3**, work after energizing, the relay releases when reaching the set value.
- X=4**, not work after energized (press reset key or short connecting reset terminal and 0V to work), the relay releases when it reaches the set value.
- X=5**, work after energizing, the relay will absorb when reaching the set value and reset automatically after 5 seconds.
- X=6**, not work after energizing (work by pressing reset key or short connecting reset terminal and 0V), the relay will absorb when reaching the set value and reset automatically after 5 seconds.

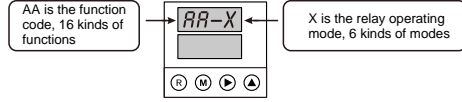

Example 1: ZN48 is used as a single setting Dual digital 4-digit time relay, the delay range is 1~9999 seconds, and the working mode is 3.

Setting procedure: Long press the shift key for 10 seconds, wait the display of "AA-X" on the upper row, then press the shift key and add key to make it display 03-3, and save the setting automatically after 5 seconds.

Example 2: ZN72 is used as a single-setting dual-digital display 4-digit frequency meter with multiplier, frequency range: 0~9999, working mode 1.

Setting procedure: Long press the shift key for 10 seconds, wait the display of "AA-X" on the upper row, then press the shift key and add the number of keys to make it display 19-1, and save the setting automatically after 5 seconds.

**F. Function Code Description**

Code	Functions	Range	Notes
01-X	Single Setting Dual digital 4-digit Time Relay	0.01s~99.99s	Positive Time delay
02-X		1m~9999m	
03-X		1s~9999s	
04-X		1s~99m59s	
05-X		1m~99h59m	
06-X	Double Setting Dual Digital 4-digit Time Relay	1m~99h59m	
07-X		1s~99m59s	
08-X		1s~9999s	
09-X		1m~9999m	
10-X	Single Setting 8-digit digital Display Timer	0~99h59m59.99s	Immediate reset
11-X		0~9999h59m59s	
12-X		0~9999d23h59m	
13-X	Single Setting dual digital display 4-digit Frequency Meter	0.1Hz~999.9Hz	Resolution of 0.1 Hz
14-X	Single-setting dual digital display 4-digit frequency meter with multiplier	0~9999	Frequency/Revolution General Purpose
15-X	Single setting 4-digit counter/meter counter	0~9999.999	
16-X	Single setting 8-digit counter/meter counter	0~99999999.999	

**Notes**

X is the relay operating mode, find page 4 for details.

D=days; H=hours; M=minutes; S=seconds; Hz=hertz.

**Function A Single Setting Dual digital 4-digit Time Relay**

**A. Instructions** (code 01~05, find page 5 for details)

- Digital tube: the upper row of four digital tubes to display the delay value, the bottom row displays the set value
- "▶" shift key: press this key to move the digit, such as second digit shifted to the first digit.
- "▲" add key: press this key to make the blinking digit increment one way.
- "R" reset key: Press this key to reset the delay value, or save and exit the setting interface.
- "M" pause key: Press this key to pause the delay; release the pause key to continue the delay.
- After reset, the delay starts and RUN lamp flashes; after the delay is finished, the relay operates according to the working mode. When OUT light is on, the relay is engaged; when OUT light is off, the relay is released.

**B. Delay value setting**

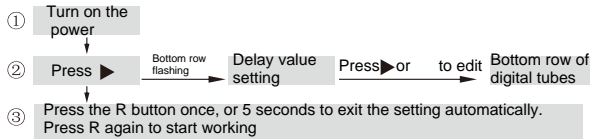

**C. Terminal function description**

- Reset terminal and 0V terminal reset after connecting; after disconnecting to re-delay.
- Pause terminal and 0V terminal connected to pause delay; disconnected to continue the delay.
- CP1, CP2 signal input and +12V output are invalid in this function.

**D. There are 6 working modes, find the description on page 4 for details.**

**Function B Double Setting Dual Digital 4-digit Time Relay (cyclic delay)**

**A. Instructions** (code 06~09, find page 5 for details)

- Digital tube: the upper row of four digital tubes sequentially display the current relay release/absorption time, and the bottom row of four digital tubes sequentially display the set value of the relay release/absorption time when it is working. The upper row of four digital tubes displays the set value of release time, and the bottom row of four digital tubes displays the set value of suction time when it is setting.
- "▶" shift key: press this key to move the digit, such as second digit shifted to the first digit.
- "▲" add key: press this key to make the blinking digit increment one way.
- "R" reset key: Press this key to reset the delay value, or save and exit the setting interface.
- "M" pause key: Press this key to pause the delay; release the pause key to continue the delay.
- After reset, the release time starts to delay, the RUN lamp flashes, after the delay is completed, the relay is absorbed and the OUT lamp is on; then the absorption time starts to delay, after the delay is completed, the relay is released and the OUT lamp is off, so the cycle works.

**B. Release and Suction Time Setting**

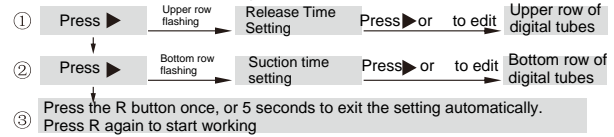

**C. Terminal function description**

- Reset terminal and 0V terminal reset after connecting; after disconnecting to re-delay.
- Pause terminal and 0V terminal connected to pause delay; disconnected to continue the delay.
- CP1, CP2 signal input and +12V output are invalid in this function.

**D. Operating Mode only has 1 and 2, find the description on page 4 for details.**

**Function C Single Setting 8-digit digital Display Timer**

**A. Instructions** (code 10~12, find page 5 for details)

- Digital tube: the eight digital tube displays the current accumulated time when it is working; the eight digital tube displays the accumulated time setting value when it is setting.
- "▶" shift key: press this key to move the digit, such as second digit shifted to the first digit.
- "▲" add key: press this key to make the flashing digit increment one-way, pressing this key during operation will display the set value.
- "R" reset key: Press this key to reset the delay value, or save and exit the setting interface.
- "M" pause key: Press this key to pause the delay; release the pause key to continue the delay.
- After reset, the timer starts to accumulate time, and the RUN lamp blinks; after the timer finishes, the relay operates and stops accumulating time, and the RUN lamp is always on. When OUT light is on, the relay will be engaged; when OUT light is off, the relay will be released.
- Support power-down memory: when the power is off, it automatically saves the total time value; when the power is on, it continues to accumulate the time.

**B. Time-accumulated settings**

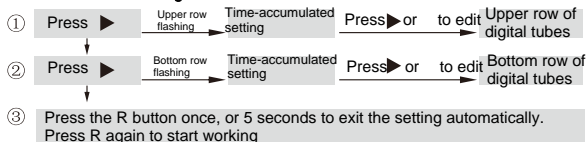

**C. Terminal function description**

- Reset terminal and 0V terminal reset after connecting; after disconnecting to accumulate.
- Pause terminal and 0V terminal connected to pause time; disconnected to continue to accumulate time
- CP1, CP2 signal input and +12V output are invalid in this function.

**D. There are 6 working modes, find the description on page 4 for details.**

**Function D Single Setting dual digital display 4-digit Frequency Meter**

**A. Instructions** (code 13~14, find page 5 for details)

- Digital tube: the upper row of four digital tubes to display the measured value, the bottom row displays the set value  
Measured value = number of signals x coefficient, coefficient range:0.001~9.999.
- "▶" Shift key: Press this key to move the digit, such as second digit shifted to the first digit.
- "▲" Add key: Press this key to make the flashing digit increment one-way.
- "R" reset key and "M" pause key are invalid.
- The measured pulse will be connected to CP1 or CP2 signal input. When the measured value reaches the set value, the relay will act, and the control value will return to the difference of five words.  
[13-X] The measured result is frequency (rpm).  
[14-X] The measured result is the rotational speed (rpm).

**B. Setting value, coefficient setting**

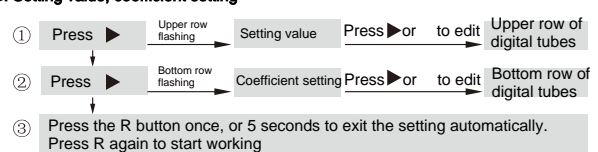

**C. Terminal Function Description**

- CP1 and CP2 are signal input terminals  
CP1 uses PNP sensor, CP2 uses NPN sensor.
- Signal input:  
a) Pulse signal: DC5~30V pulse level  
b) Contact signal: Relay contact, travel switch.  
c) Sensor signal: Photoelectric switch, proximity switch, Hall switch.

### D. Signal Inputs

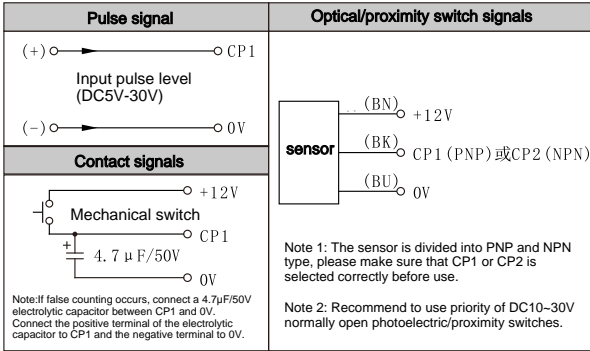

E. Operating Mode only has 1 and 3, find the description on page 4 for details.

When the operating mode is 3, the relay is engaged after 3 seconds of power-up and released when the set value is reached.

### Function E Single Setting Digital Counting/Meter Relay

#### A. Instructions (code 15~16, find page 5 for details)

- Digital tube: 15-X upper row of four digital tubes display counting value, the lower row displays the set value
- 16-X eight digits display count value
- Count value = counting signal number x multiplier, multiplier range: 0.001~9.999 (multiplier is also called coefficient, when the multiplier is 1, it can be used as a counter)
2. ▶ Shift key: press this key to move the digit, such as second digit shifted to the first digit.
3. ▲ " Add key: press this key to increment the number of blinking digits in one direction.
4. "R" Reset key: press this key to reset the count value, or save and exit the setting interface
5. "M" pause key: invalid
6. Counting frequency = 600 times/sec; Power down memory: Support.

#### B. Counting value, multiplier value setting

(1) 15-X single setting dual digit display 4- digits with Multiplier Counter / Meter Counter

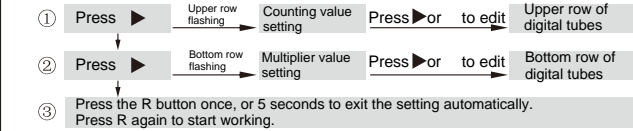

(2) 16-X Single Setting Display 8- Digits with Multiplier Counter/Meter Counter

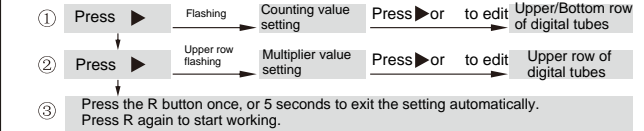

### C. Multiplier calculation

1. Meter Counter unit is meters, use meter wheel GK-80A as an example: connected to the green line when the multiplier is set to 0.01; connected to the white line, the multiplier is 0.1, and so on.

2. Sensor meter counting multiplier calculation: If the moving length is L, generating P pulse signals, then L divided P (L/P) is the desired multiplier.

Example 1: connected to the encoder of roller diameter is 0.05 meters, the encoder every turn to produce 100 pulse signals, then:

$$\text{Multiplier} = \frac{L}{P} = \frac{\text{Roller diameter}}{\text{Number of pulses for one turn of encoder}} = \frac{3.1416 \times 0.05}{100} \approx 0.0016$$

Example 2: connected to the sensor of roller diameter is 0.05 meters. For each turn of the roller, the sensor generates a pulse signal, then:

$$\text{Multiplier} = \text{Roller diameter} = 3.1416 \times 0.05 \approx 0.16$$

### D. Terminal Function Description

- Reset terminal and 0V terminal reset after connecting; recount after disconnecting
- CP1 and CP2 are signal input terminals
- CP1 uses PNP sensor, CP2 uses NPN sensor.
- Signal input
  - Pulse signal: DC5~30V pulse level.
  - contact signal: relay contact, travel switch
  - Sensor signal: photoelectric switch, proximity switch, Hall switch

### E. Signal Inputs

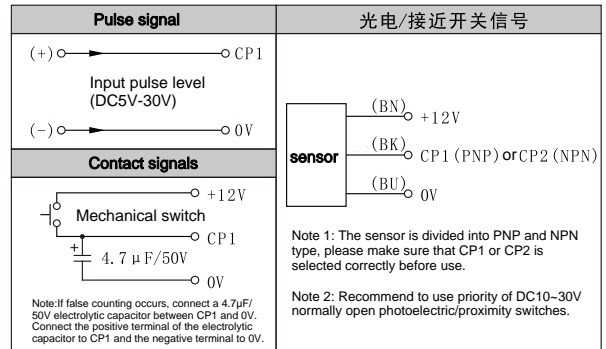

F. Operating Mode only has 1, 3 and 5, find the description on page 4 for details.

#### \*Ordering instructions

Ordering must specify the product model, operating voltage, quantity

Example:

- 1) ZN48 AC/DC100~240V 500 pcs
- 2) ZN72 AC/DC100~240V 500pcs